



Nutzen Sie die Sicherheit einer großen Marke.



5 Jahre Garantie.

Auf WK Wohnen Möbel ist Verlass.

Die Garantiebestimmungen, Gebrauchs- und Pflegeanweisungen sind im WK Wohnen Möbel-Gütepass geregelt.



Servicetelefon

Haben Sie Fragen oder Verbesserungsvorschläge?

Dann rufen Sie uns an!

24 - Stunden - Service über das WK Wohnen Servicetelefon.



Individualität

Die WK Wohnen Produktkennzeichnung belegt, dass Sie ein Unikat gekauft haben.



Pflege

Wir empfehlen WK Wohnen-Pflegeprodukte.

Lederpflege & Reinigung
Stoff-/ Mikrofaserpflege & Reinigung
Holzpflege und Sonderprodukte



Zu bestellen bei Ihrem Handelspartner,
oder unter www.wk-wohnen-care.com
bzw. unter der kostenlosen Beratungsnummer
+ 49 (0) 800 / 00 08 008.

Bei Fragen sprechen Sie uns bitte an;
wir helfen Ihnen gerne weiter.

Zur Werterhaltung Ihrer Möbel.

Standardkorpus WK mit 3mm Lochreihe

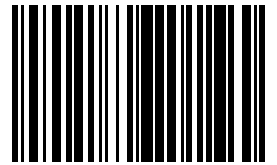

SAP 1729359

Empfohlene Werkzeuge / Recommended Tools

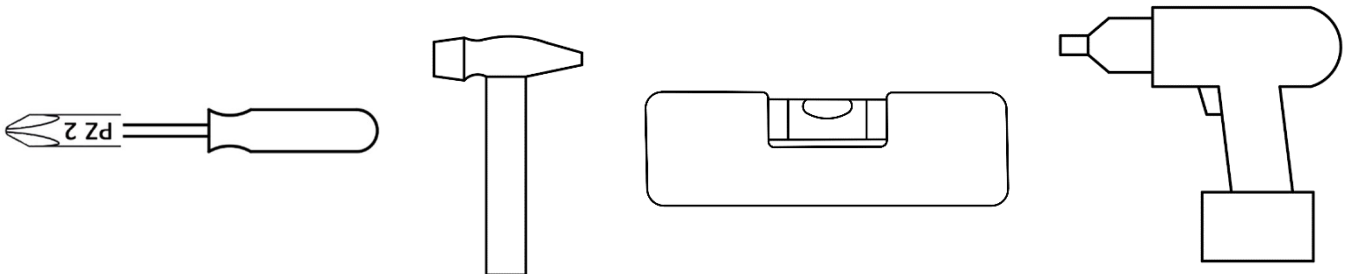

Beiliegendes Material (BB = Beschlagbeutel Nr.) / Enclosed material (BB = Fitting bag no.):

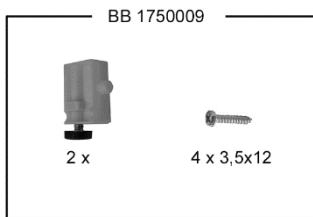
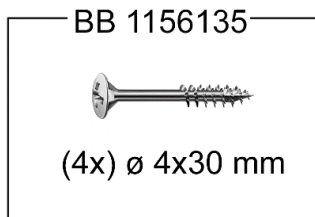
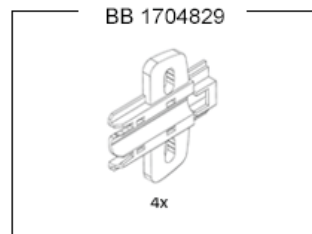
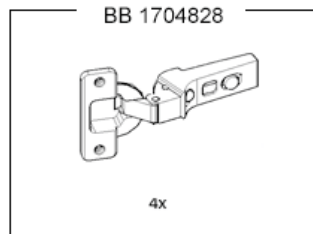
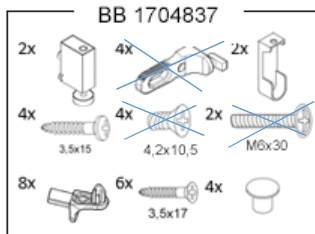

Modellbeispiele / Examples:

Achtung bitte vor der Montage mit dem Kunden klären in welchem Element Tür oder Innenbeleuchtungen vorgesehen sind !!
sehen Sie dazu bitte unsere zusätzlichen Anleitungen (Schranktüren mit LED und Einlegeböden mit Beleuchtung)

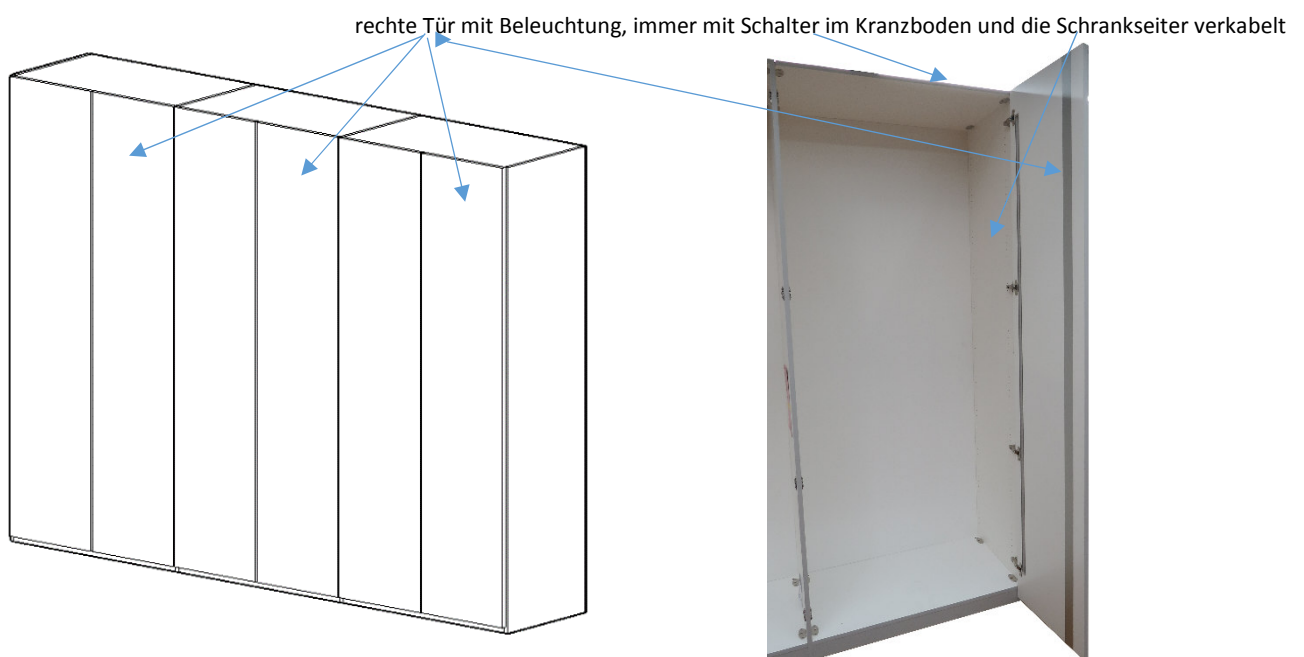

Please make sure that the door or interior lighting is provided before assembling with the customer!
Please see our additional instructions (wall-mounted luminaires with LED and lighting panels with lighting)

Standardkorpus WK mit 3mm Lochreihe

1 BB 1704837 + BB 1750000

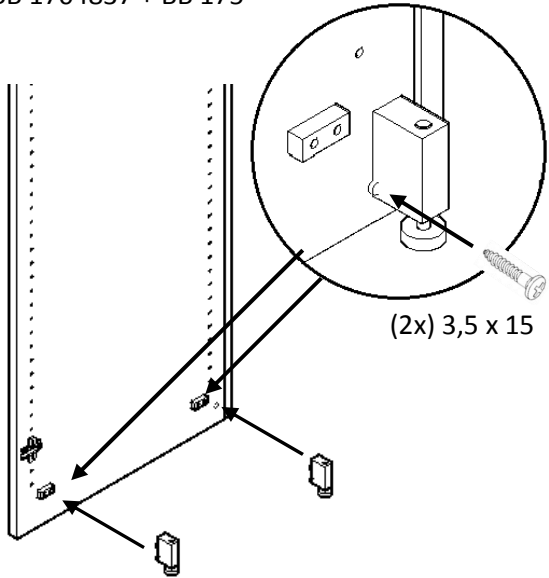

2

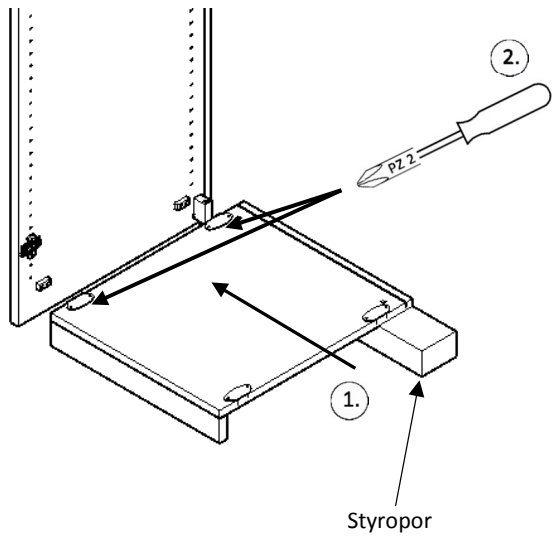

3

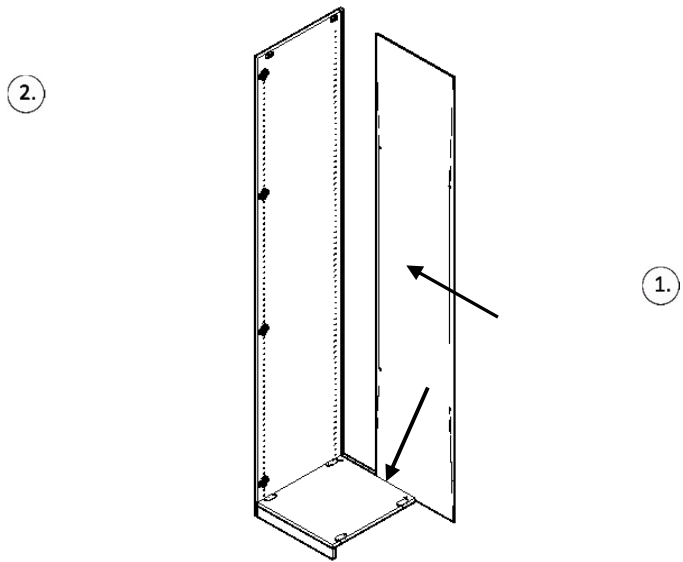

4

Infrarotschalter f. Innenbeleuchtung oder Schranktür ? siehe Seite 1+4
Infrared switch f. Indoor lighting or barrier door ?? see page 1+4

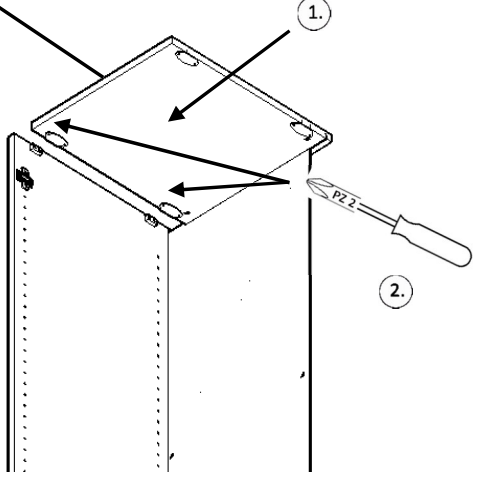

5

Kabel für die Innenbeleuchtung oder Schranktür ?? siehe Seite 1+4
Cables for interior lighting or barrier door ?? See pages 1 + 4

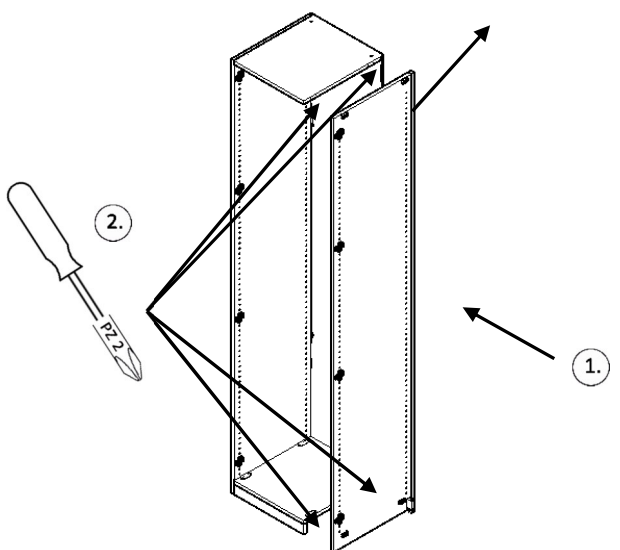

6

Achtung Tür mit Beleuchtung dann re. Seite verkabelt !!!!
Attention door with lighting then right side cabled !!!!

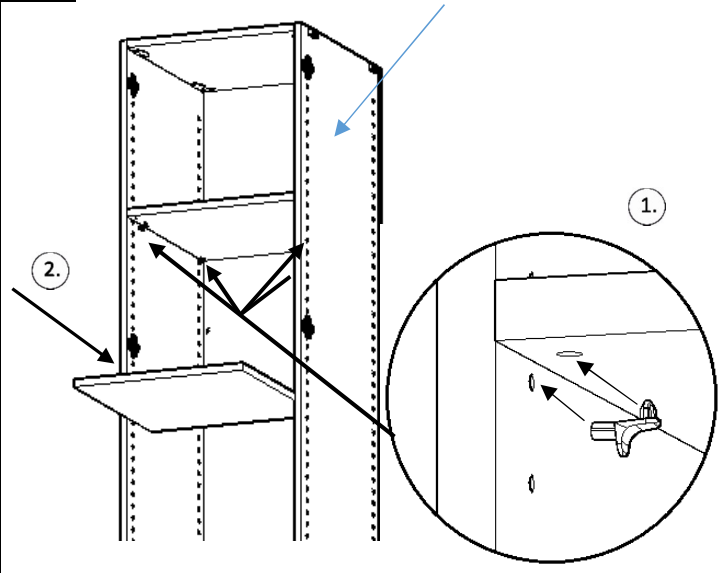

Standardkorpus WK mit 3mm Lochreihe

7 BB 1156135

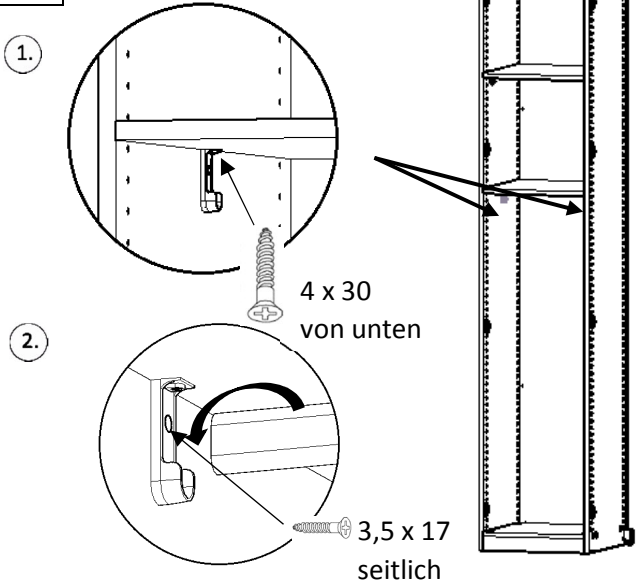

8

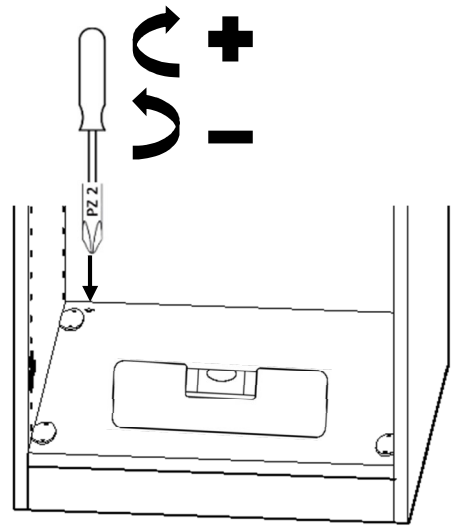

9

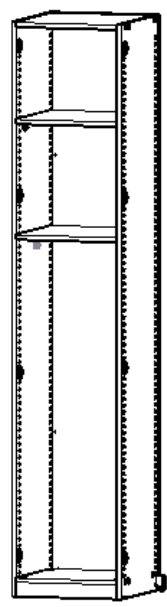

10

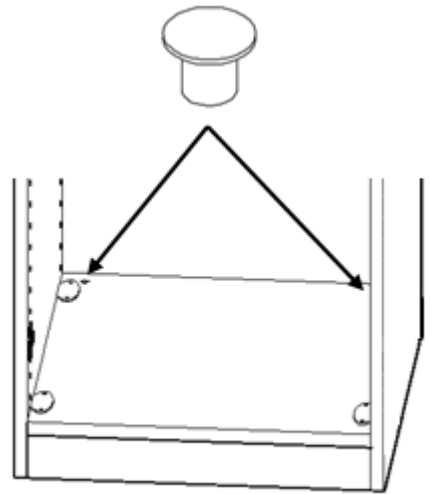

Schritt 1-10 Wiederholen / Repeat step 1-10

11 BB 1704829

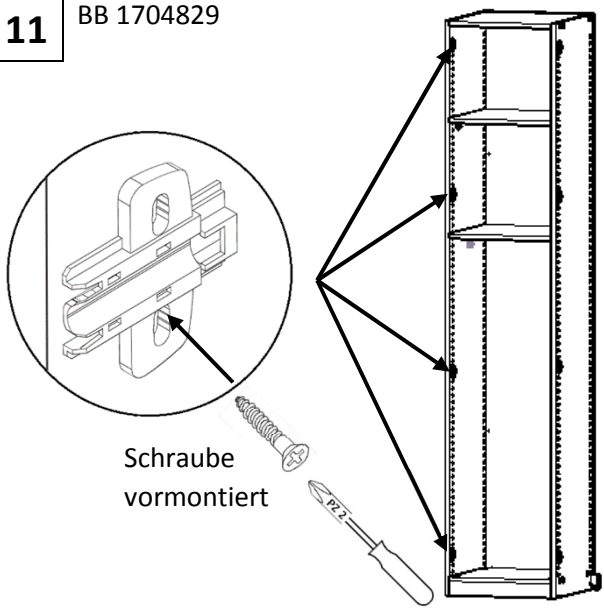

12 BB 1704828

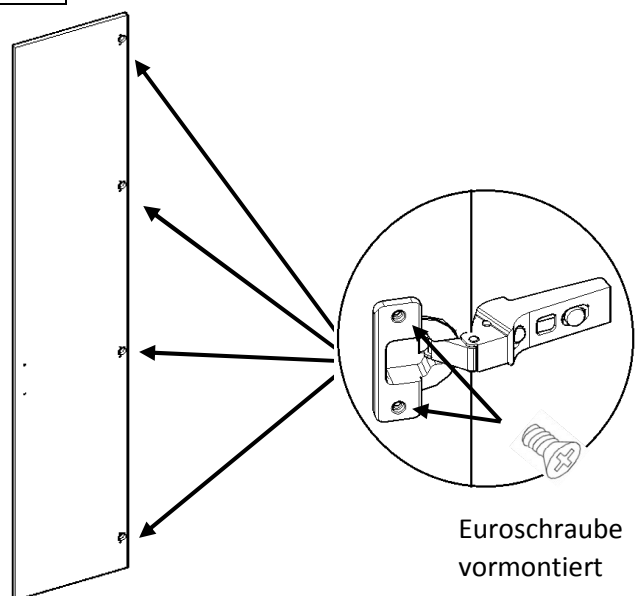

Standardkorpus WK mit 3mm Lochreihe

13

Tür / door

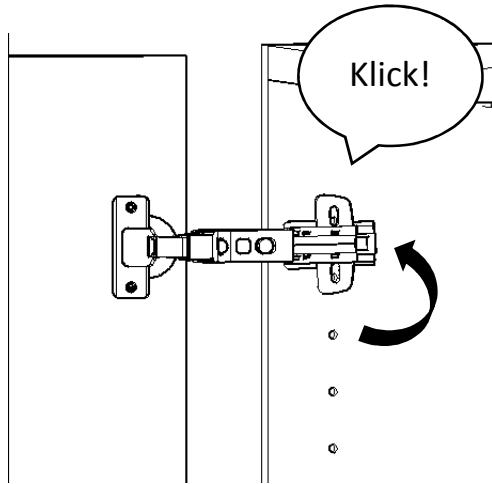

14

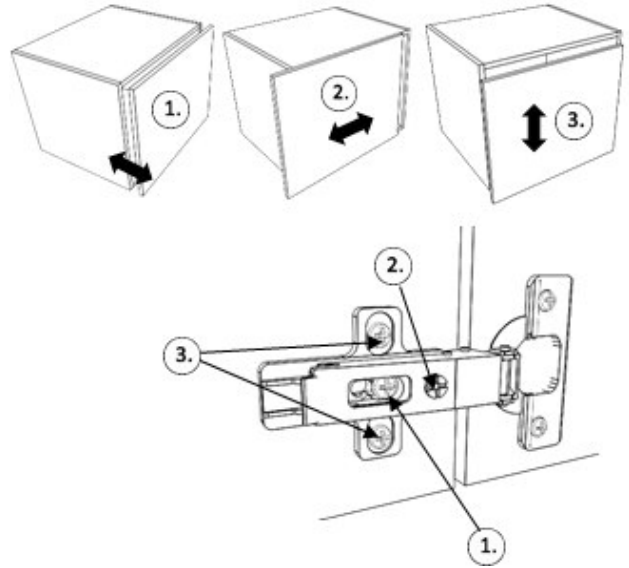

bitte die Schaltskizze der Schrankbeleuchtung (Türen) beachten (optional 0180 / 0181)
Please note the dashboard of the cabinet lighting (doors) (optional 0180/0181)

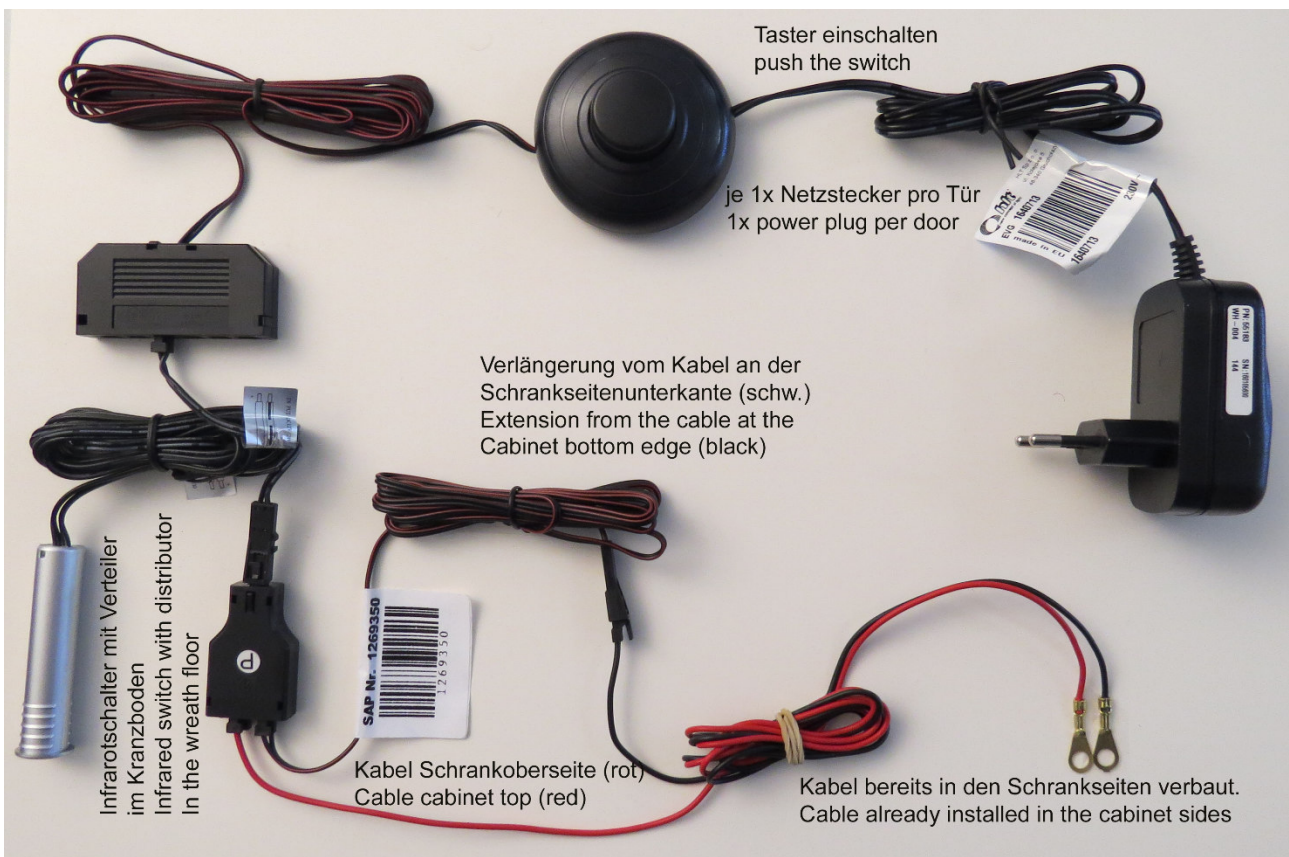

Falttürenschränk mit 3mm Lochreihe



SAP 1729360



Empfohlene Werkzeuge / Recommended Tools

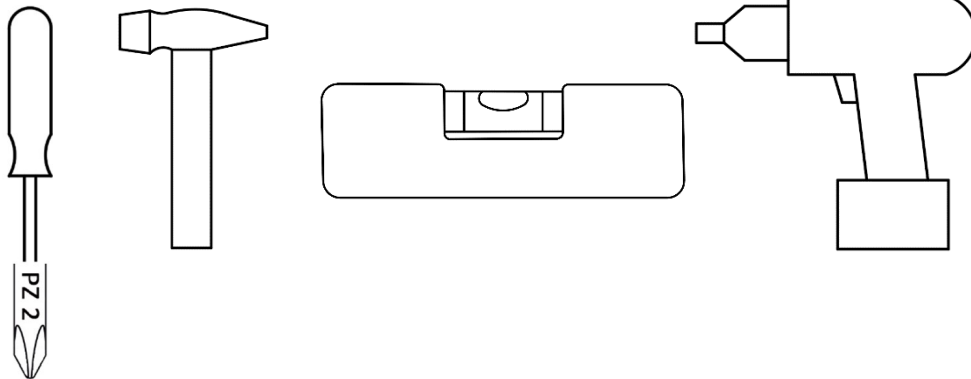

Beiliegendes Material (BB = Beschlagbeutel Nr.) / Enclosed material (BB = Fitting bag no.):

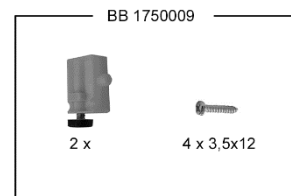
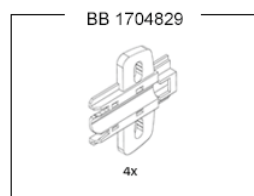
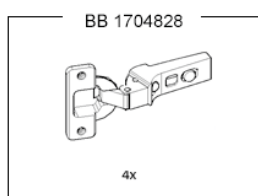
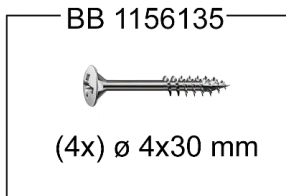
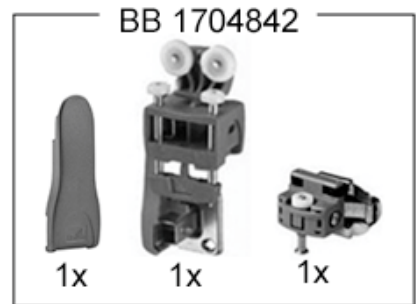
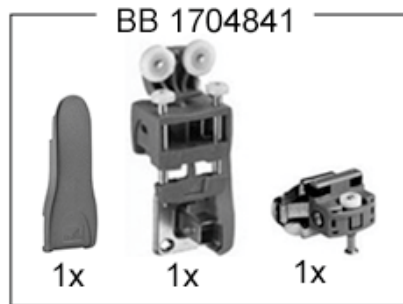
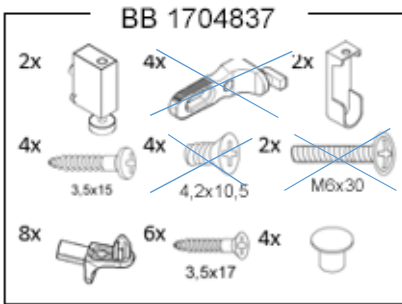

Modellbeispiele / Examples:

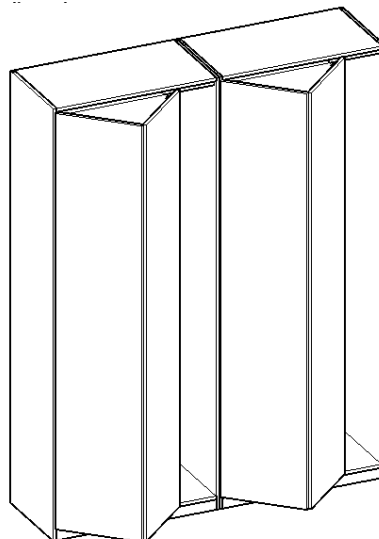

Falttürenschränk mit 3mm Lochreihe

1

BB 1704837
BB 1750009

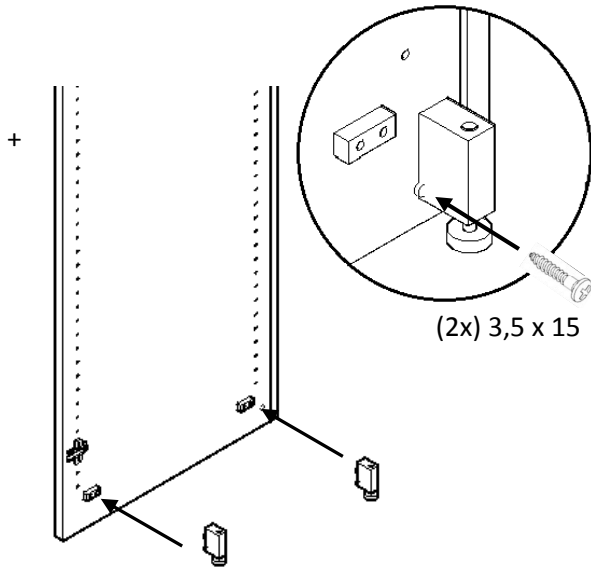

2

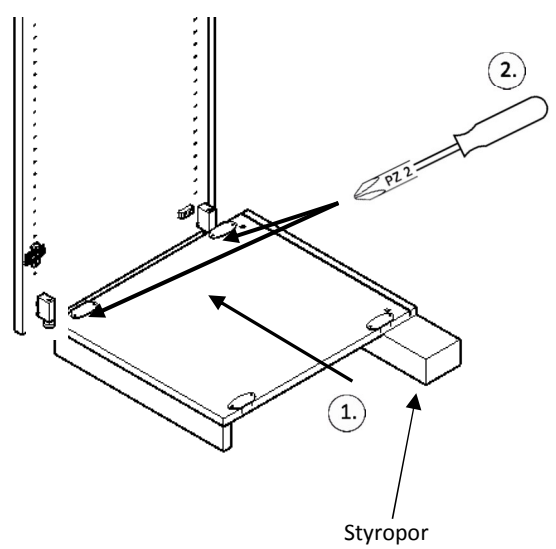

3

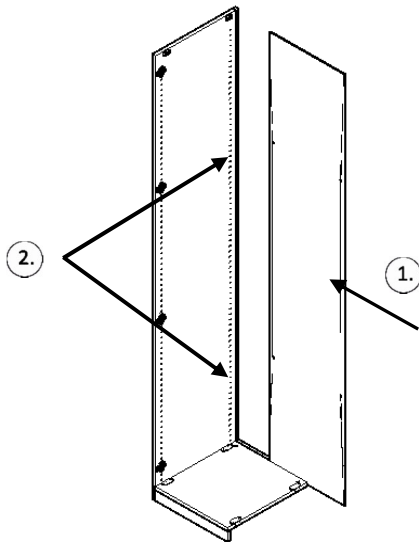

4

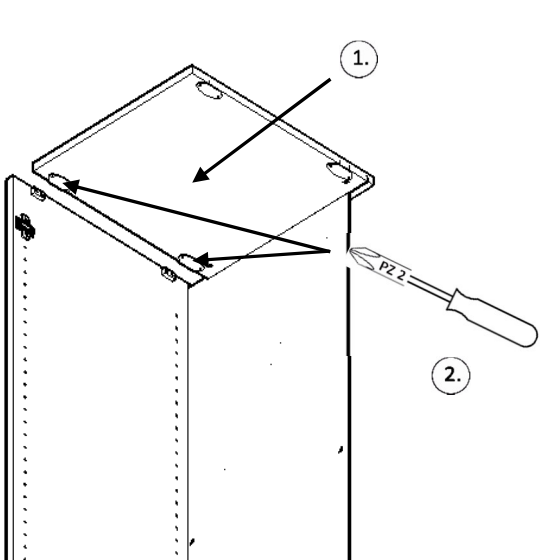

5

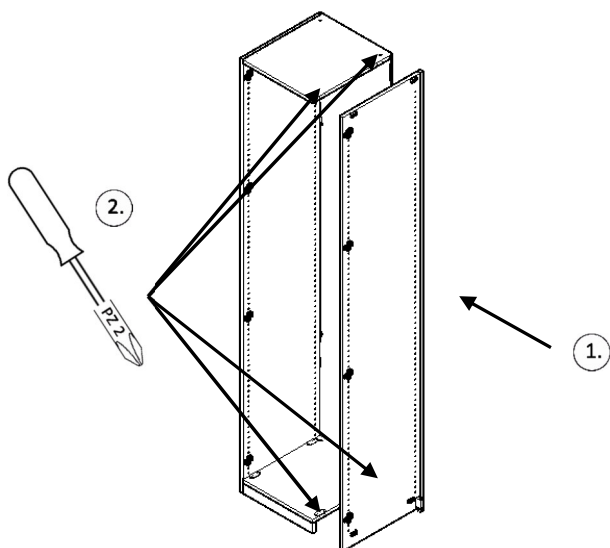

6

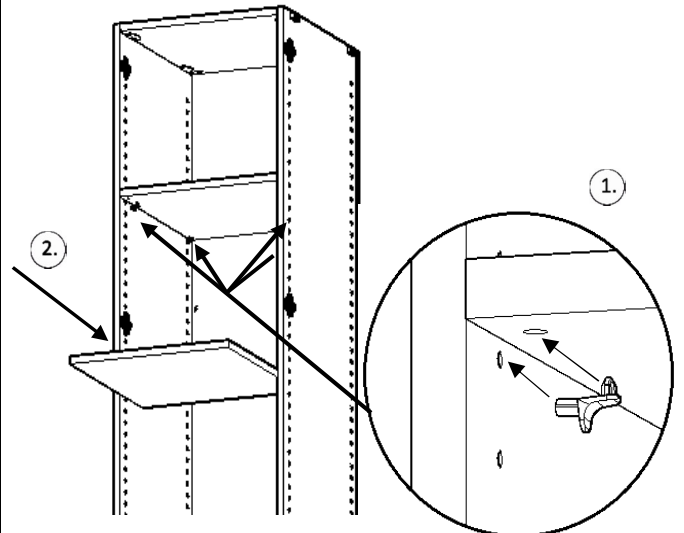

Falttürenschränk mit 3mm Lochreihe

7 BB 1156135 + BB1704837

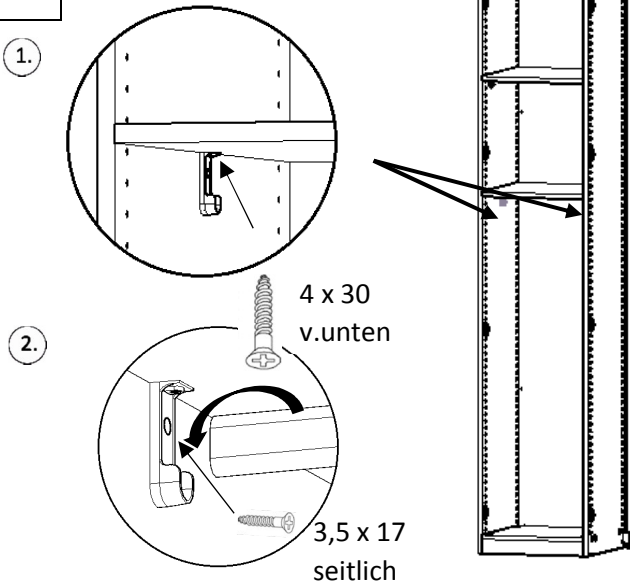

8 Schraube von unten

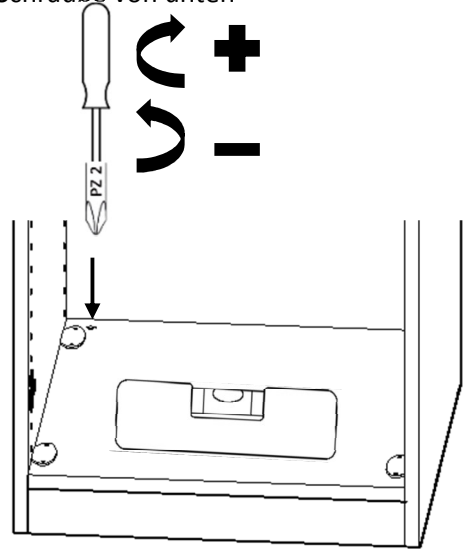

9

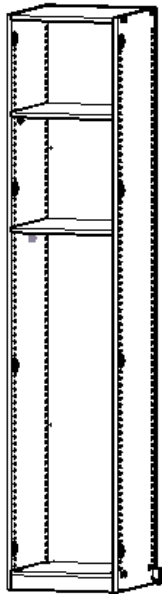

10

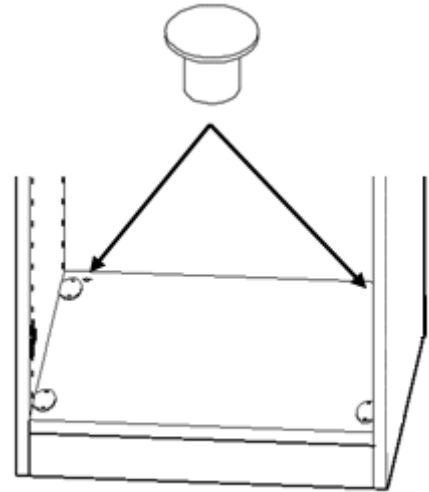

Schritt 1-10 Wiederholen / Repeat step 1-10

11 BB 1704829

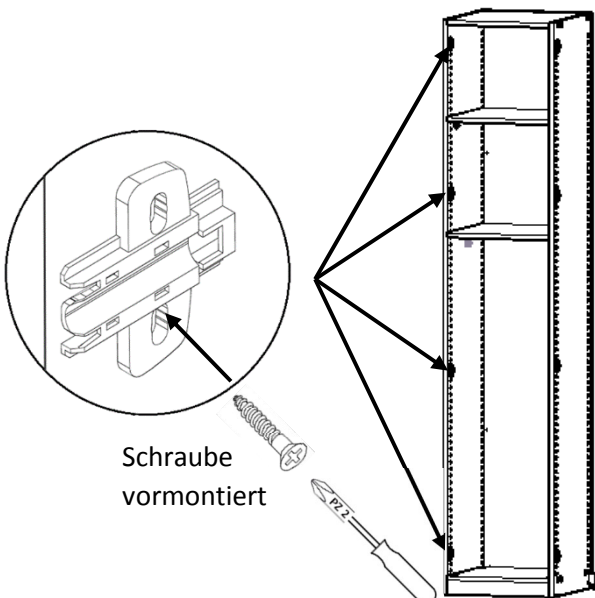

12 BB 1704828

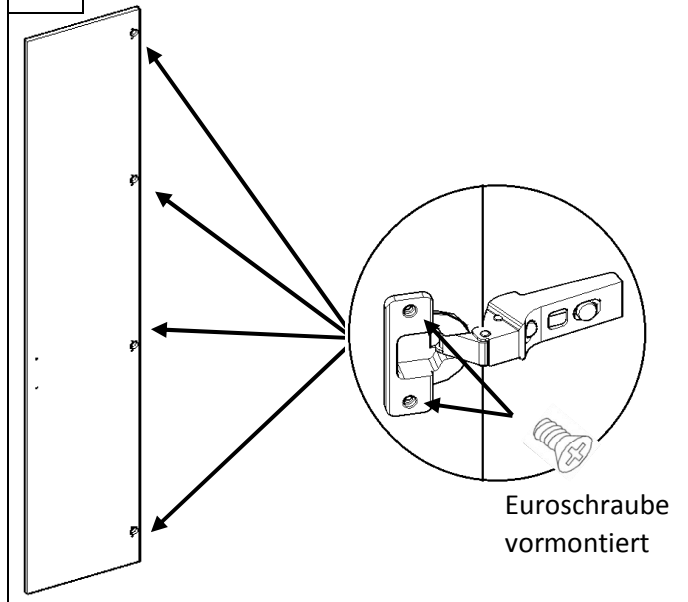

Falttürenschränk mit 3mm Lochreihe

13

Anschlagtür / stop door

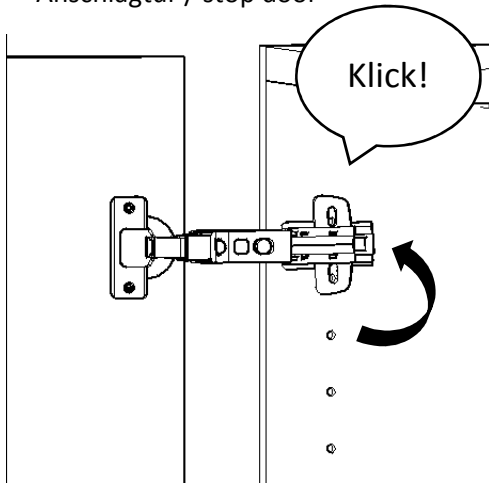

14

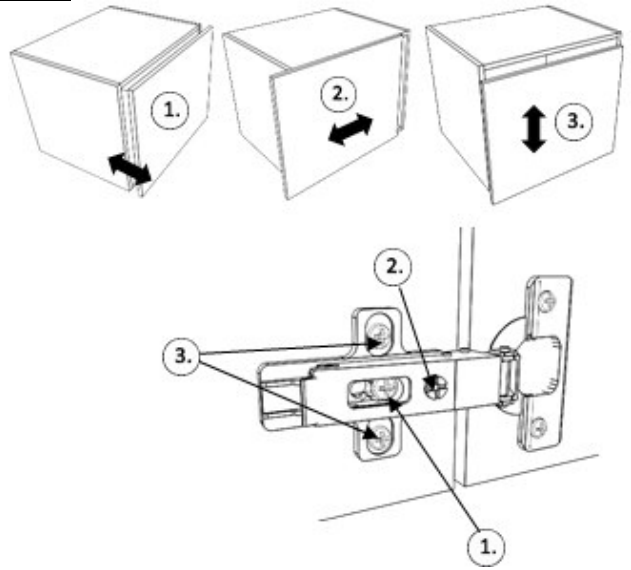

15

BB 1704841 / 42

Zugtür / pull door

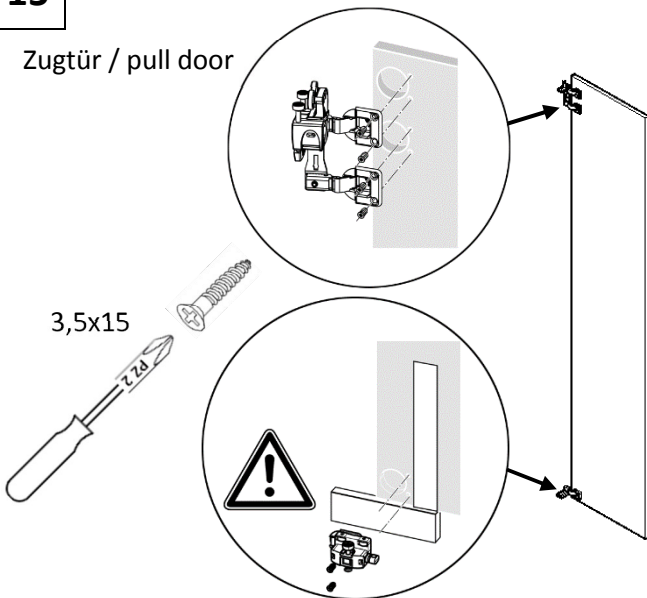

16

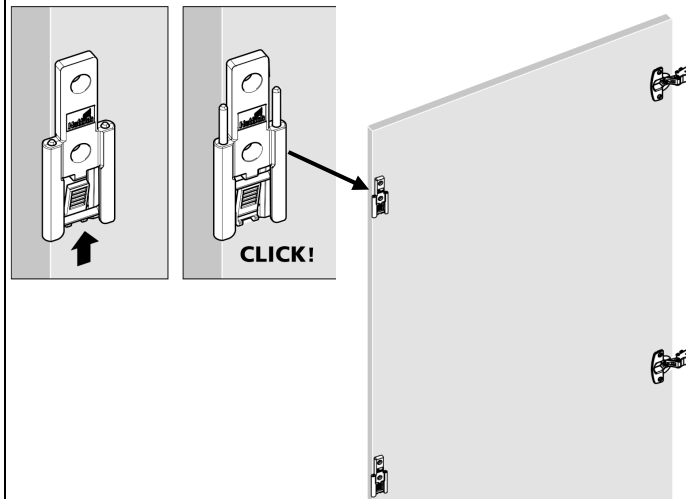

17

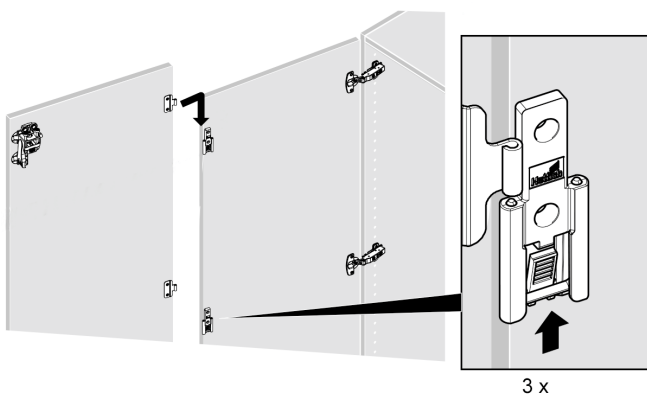

18

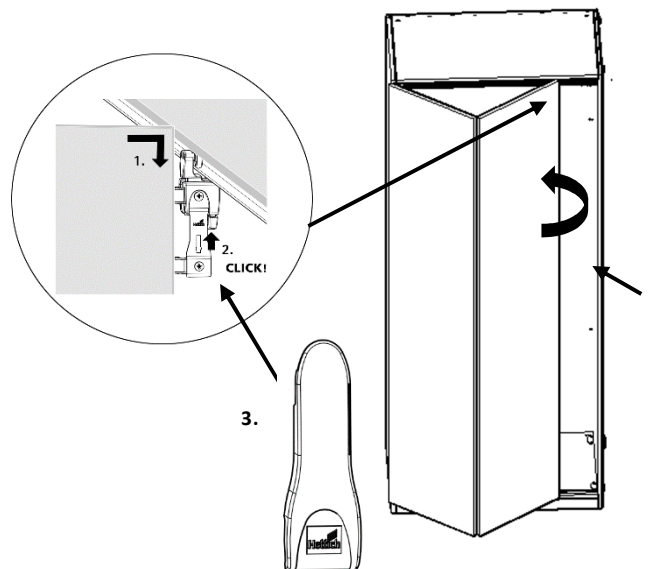

Falttürenschränk mit 3mm Lochreihe

19

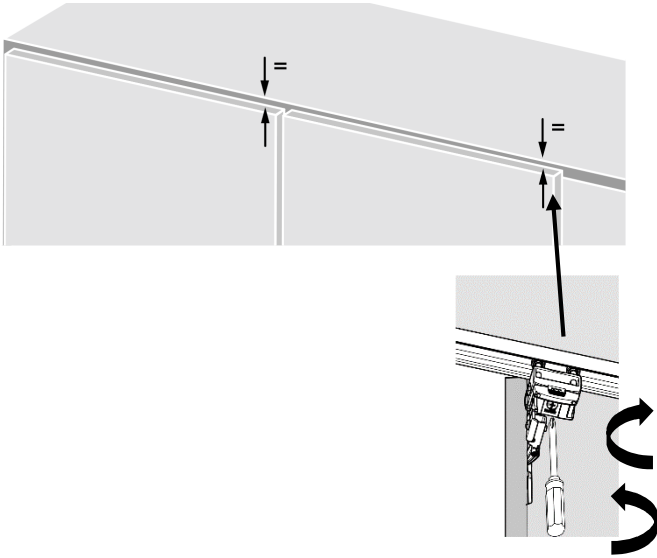

20

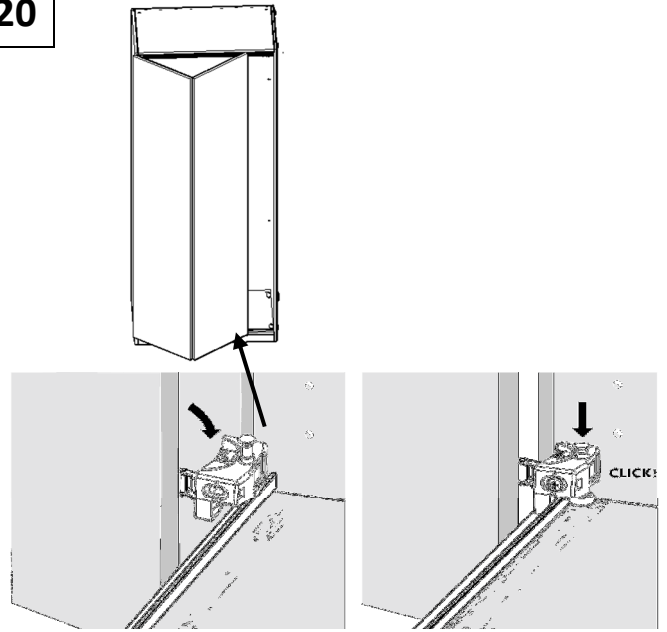

21

Tür über Spannvorrichtung gerade ziehen /
pull door straight

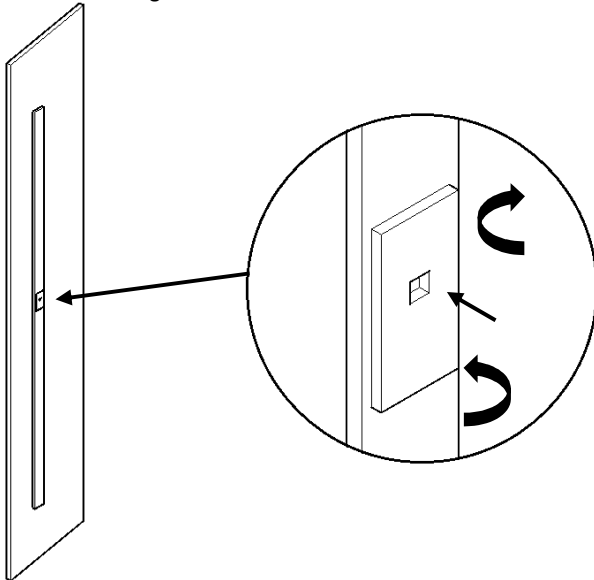

22

23

24

Eckkorpus 1T.



Empfohlene Werkzeuge / Recommended Tools

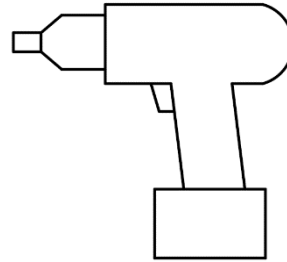
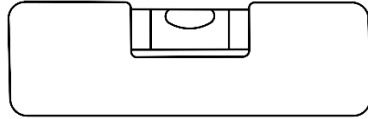
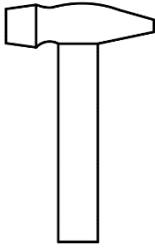
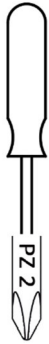

Beiliegendes Material (BB=Beschlagbeutel Nr.) / Enclosed material (BB=Fitting bag no.):

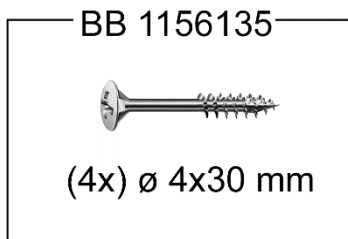
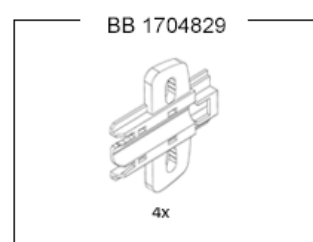
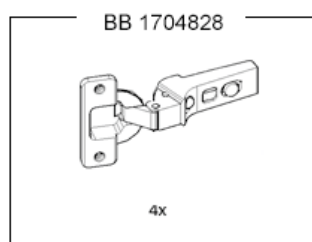
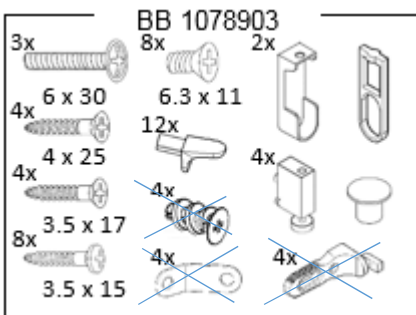

Modellbeispiele / Examples:

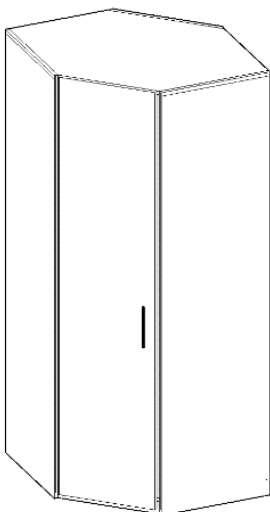

Eckkorpus 1T.

1

BB 1078903

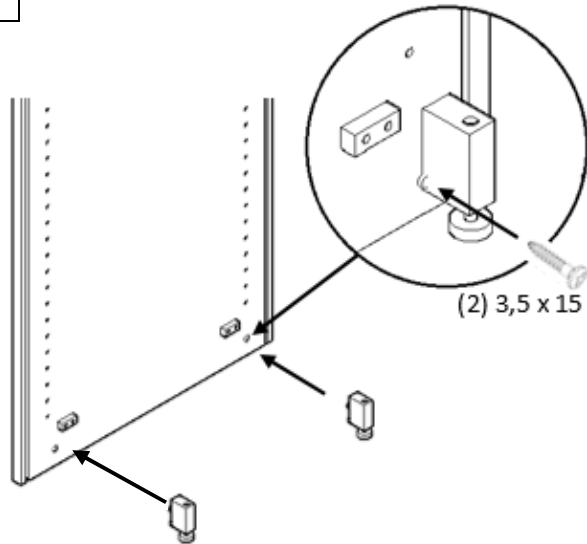

2

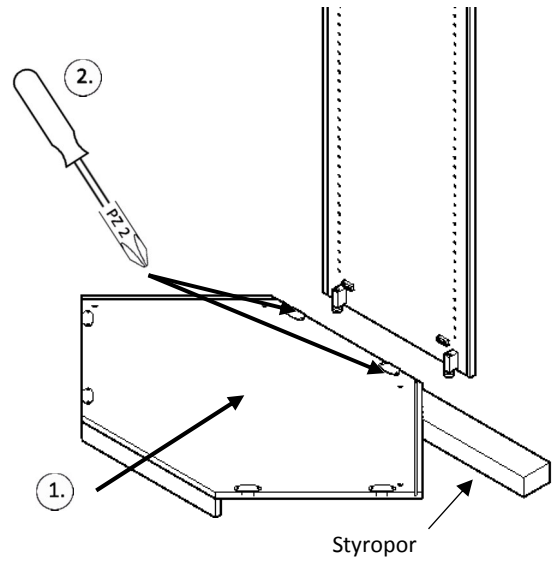

3

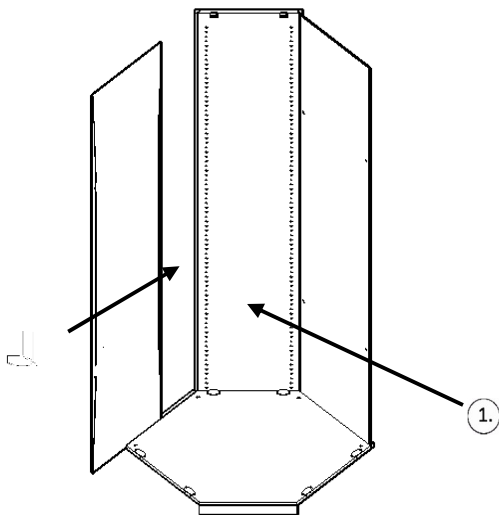

4

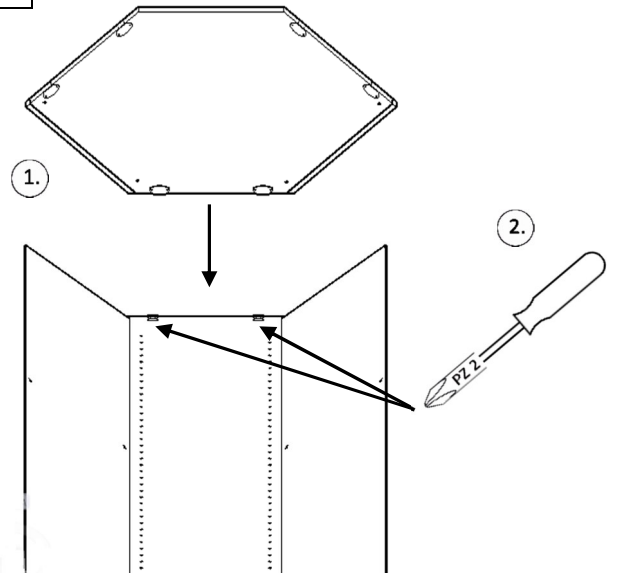

5

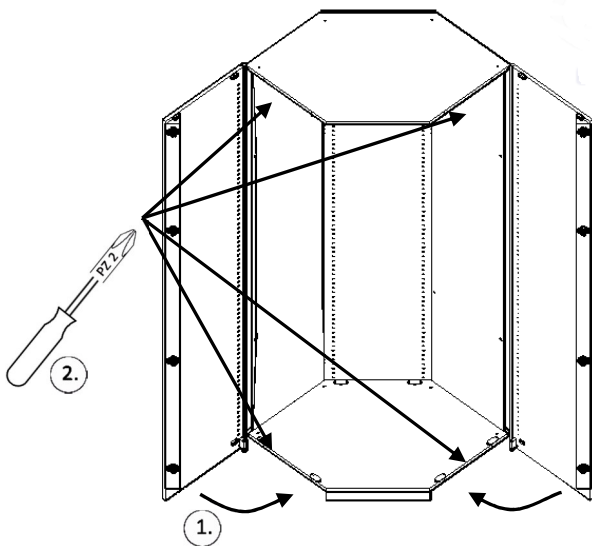

6

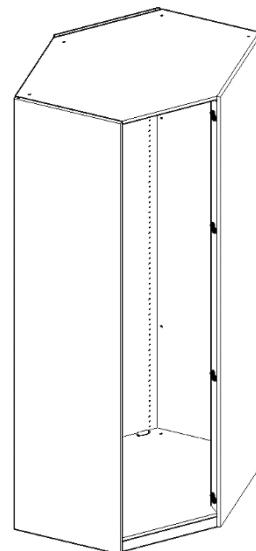

Eckkorpus 1T.

7

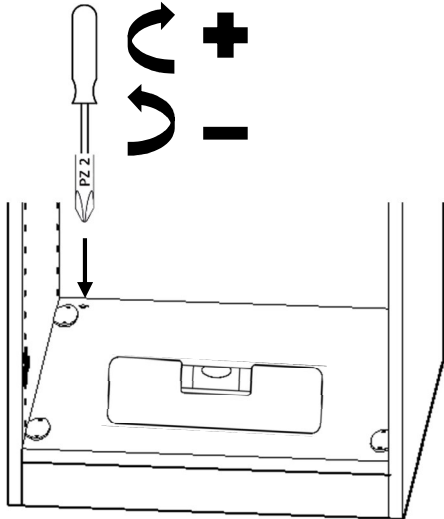

8

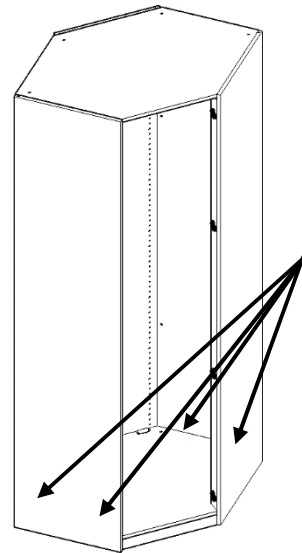

9

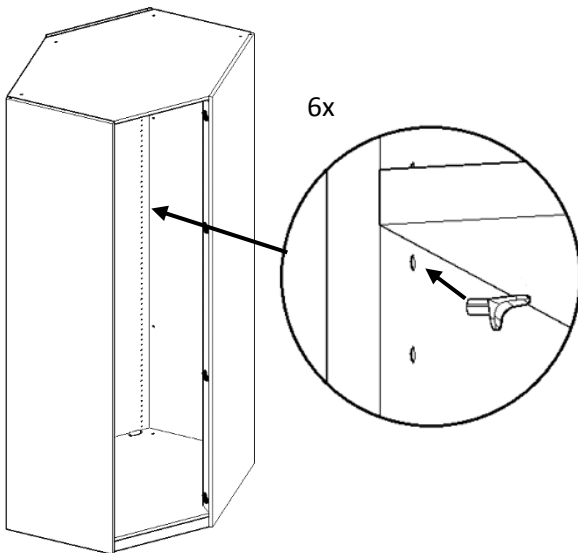

10

BB 1156135 + BB1078903

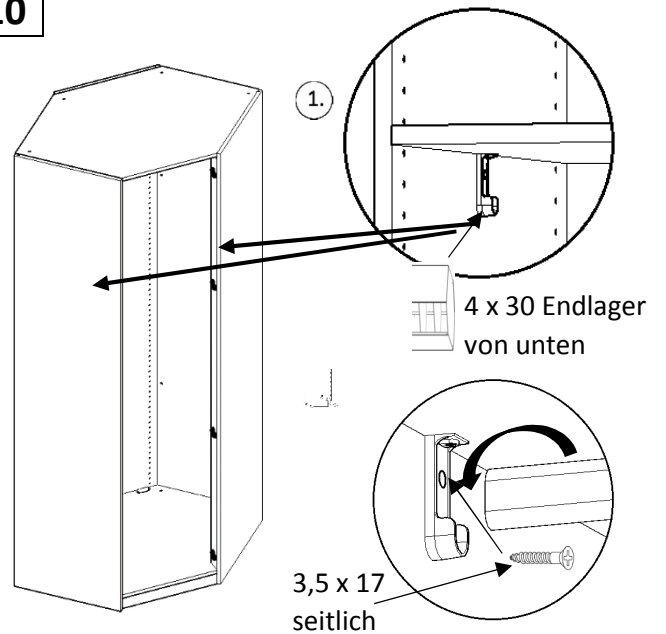

11

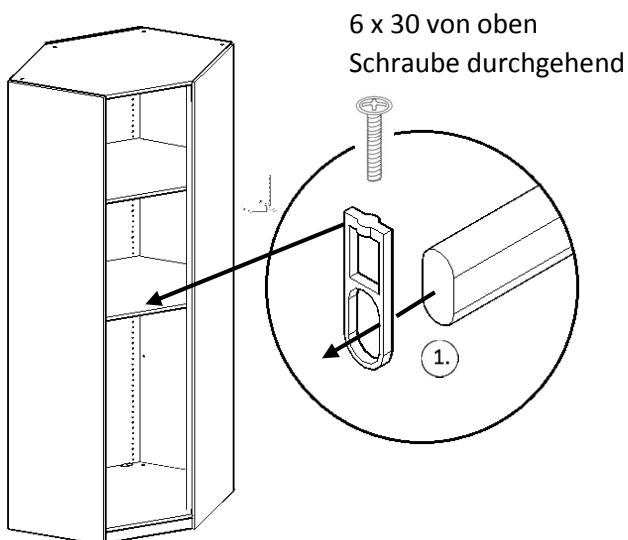

12

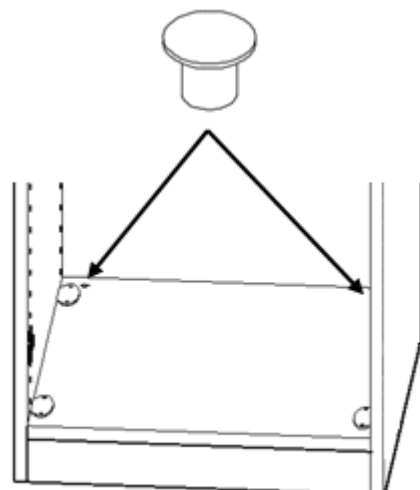

Eckkorpus 1T.

13

Abstandsleiste bei GLS-Anbau-Übergang GLS

If GLS-extension add a spacer bar

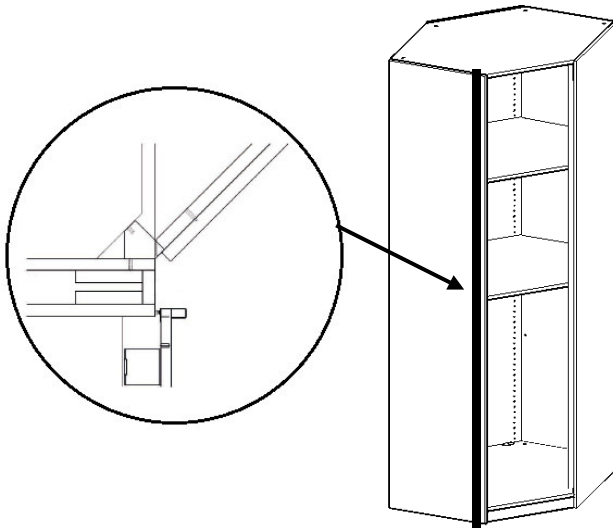



Bitte beachten Sie beim Aufbau unbedingt die Montageanweisung für Ihre neuen Möbel. Der Aufbau und die Montage dürfen ausschließlich durch autorisiertes Fachpersonal erfolgen. Bei Folgeschäden, verursacht durch eventuelle Selbstmontage oder Nichtbeachtung wichtiger Produkt- oder Montageinformationen, wird keine Haftung übernommen. Kontrollieren Sie vor der Montage, ob alle Teile vollständig und ohne Beschädigung angeliefert wurden.

Konstruktions-, Farb- und Materialänderungen im Rahmen des technischen Fortschritts bleiben uns als Lieferant vorbehalten.



Bitte dem Kunden übergeben.
Please hand over to the customer.

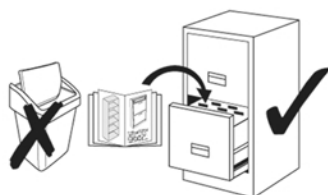

Erforderliches Aufbaupersonal:
Personnel required for assembly: 07.07.2017 Rh.

Flächenbündiger Schiebetürenschränk / Flashed sliding door wardrobe

Inhalt / Contents	Seite / Page
1. Bauteil Übersicht ,benötigtes Werkzeug , beiliegendes Material Component index, needed tools, the enclosed material	3
2. Aufbauanleitung Schrankkorpus und Schienenmontage Assembly instruction Wardrobe carcass and rail	4 - 9
3. Frontenmontage front fitting	10 - 12
4. Fronten ausrichten Adjust doors	13 - 14

Korpuseinteilung / Compartmentation

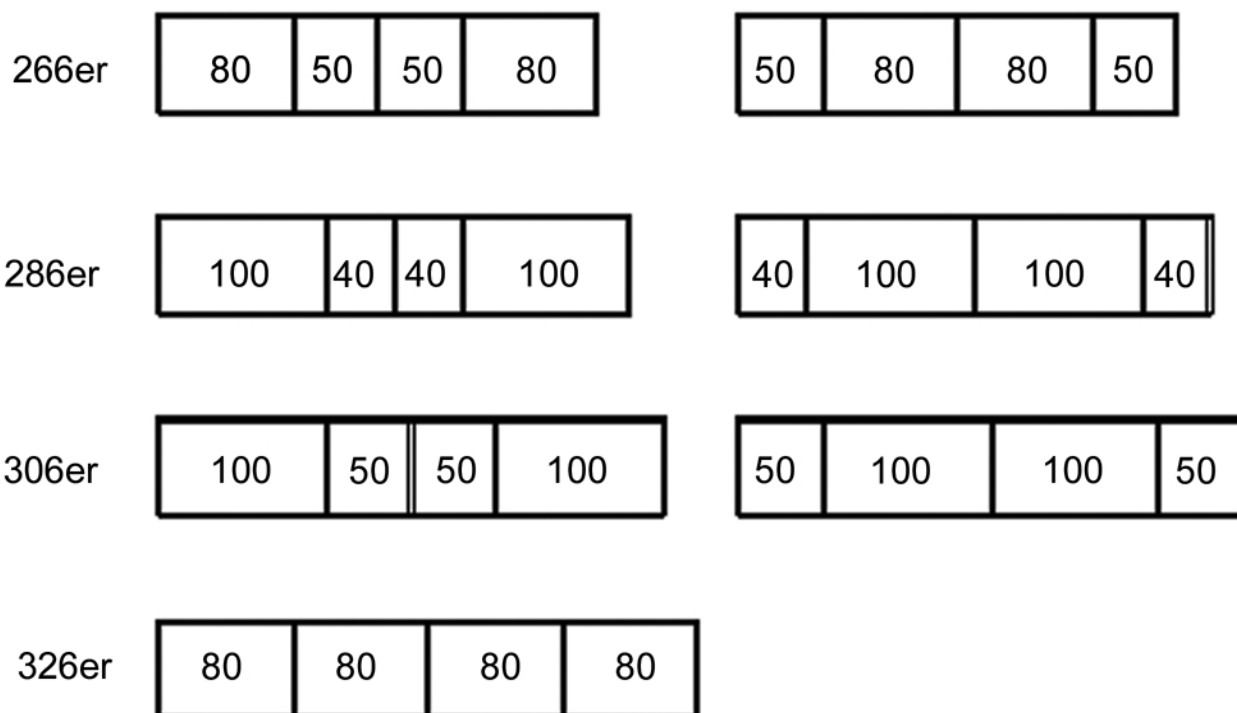

Flächenbündiger Schiebetürenschränk / Flashed sliding door wardrobe

Für die Montage wird benötigt:

Required for assembly:



Beiliegendes Material (Beschlagbeutel Nr.):
Enclosed material (Fitting bag no.):

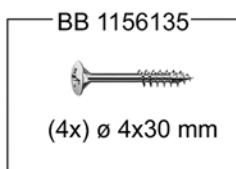
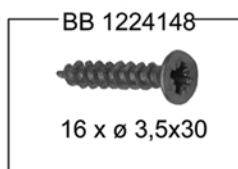
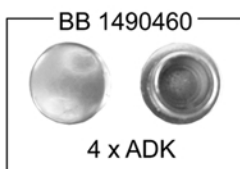
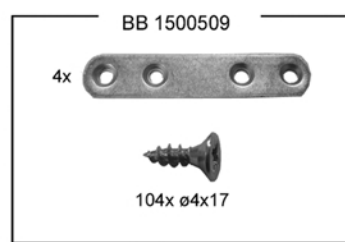
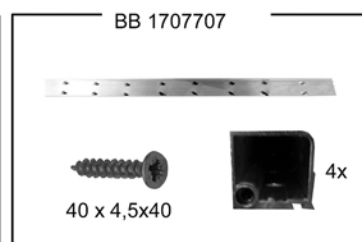
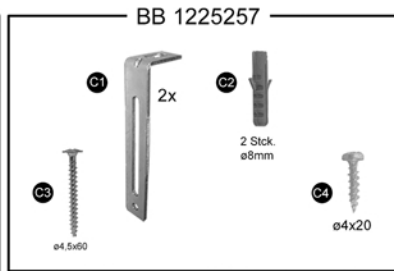
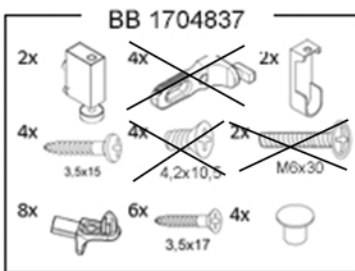

↑
nur wenn bestellt / only when ordered



Führungsschiene oben / Guide rail above



Führungsschiene unten / Guide rail below

Flächenbündiger Schiebetürenschränk / Flashed sliding door wardrobe

Achtung! ✓

Vor der Montage bitte mit dem Kunden klären ob in einem Element beleuchtete Einlegeböden vorgesehen sind ???
 ist dieses der Fall bitte Kranzböden mit einem Infrarotschalter einbauen. (siehe Seite 16)

Important! ✓

Before installation, please clarify with the customer Whether lit in an element illuminated shelves are provided?
 This is the case please wreaths with one Install the infrared switch. (see page 16)

Vor dem Verschieben des Schrankes müssen die Sockelstellschrauben hochgedreht werden!

Before relocating the wardrobe the adjusting screws in the socket have to be screwed upwards!

④ Kranz links / mitte / rechts Wreath left / center / right

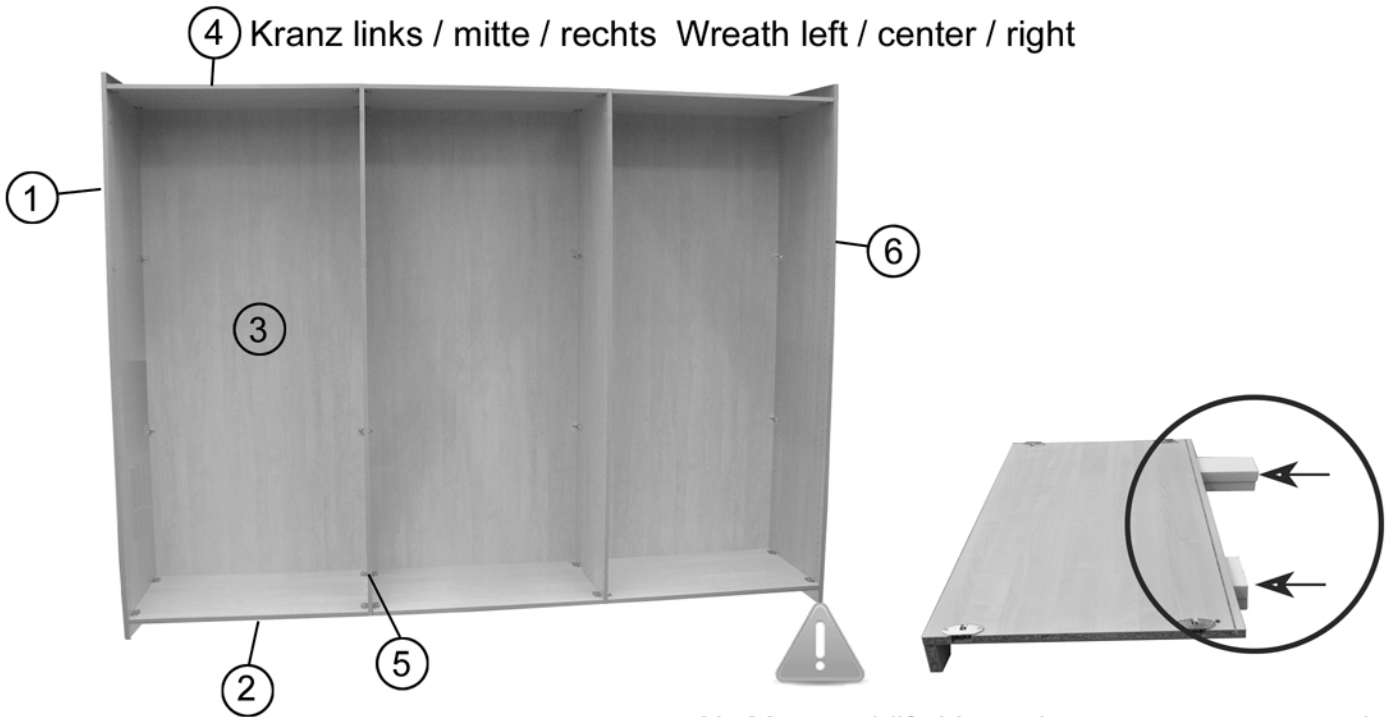

Als Montagehilfe Verpackungsstyropor verwenden
 Use as an assembly aid styrofoam packing

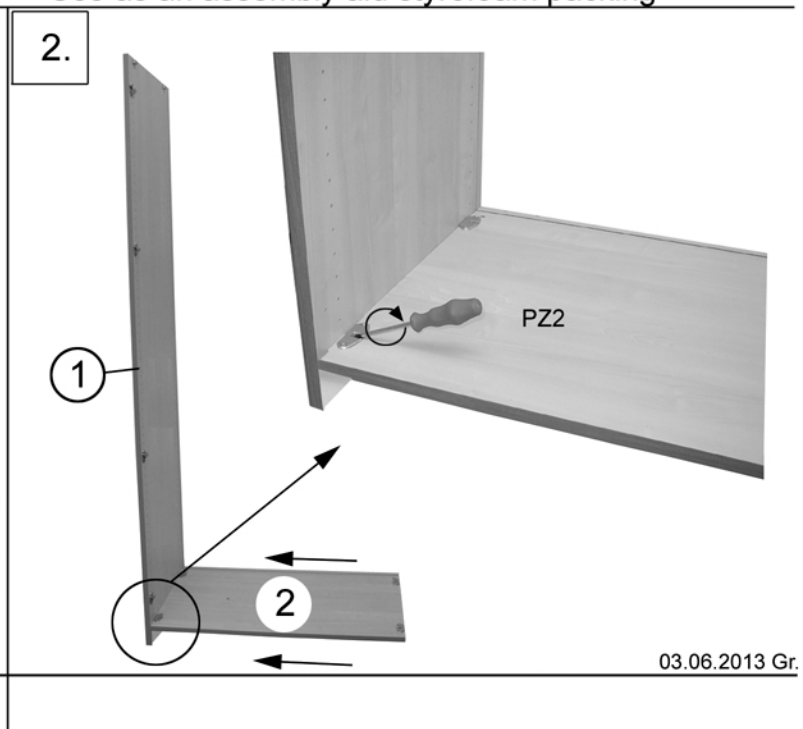
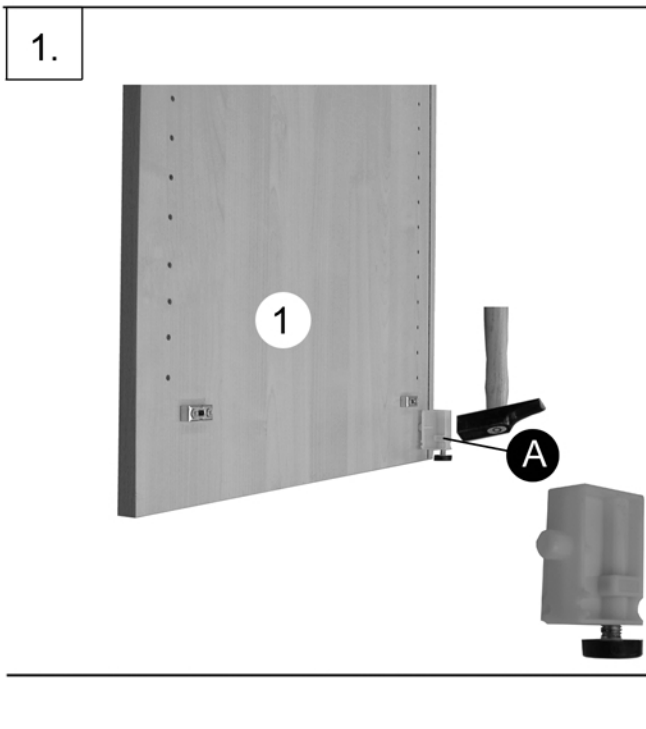

Flächenbündiger Schiebetürenschränk / Flashed sliding door wardrobe

3.

Für die Montage von **beleuchteten E-Böden** die **Bohrung in der Rückwand** berücksichtigen
 Please pay attention to the holes at the back panels for the assembly of illuminated shelves



4.

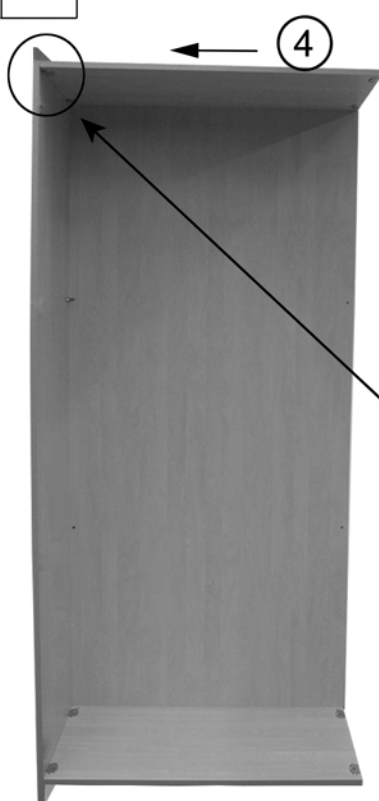

Achtung Kranz links / rechts
 Attention cornice left / right



Muffe / sleeve

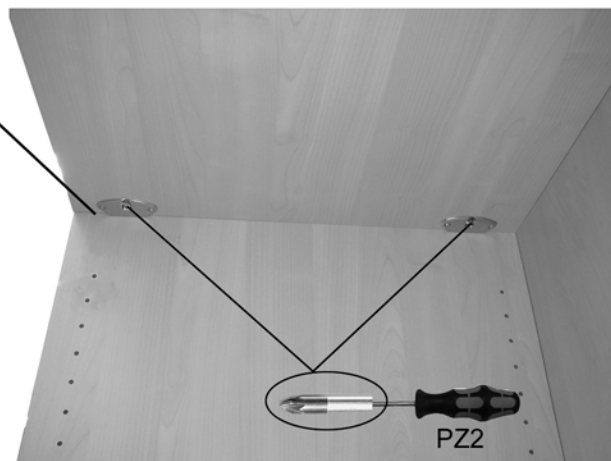

Flächenbündiger Schiebetürenschrack / Flashed sliding door wardrobe

- 5. Wiederholung Punkt 2-4
Repeat point 2-4

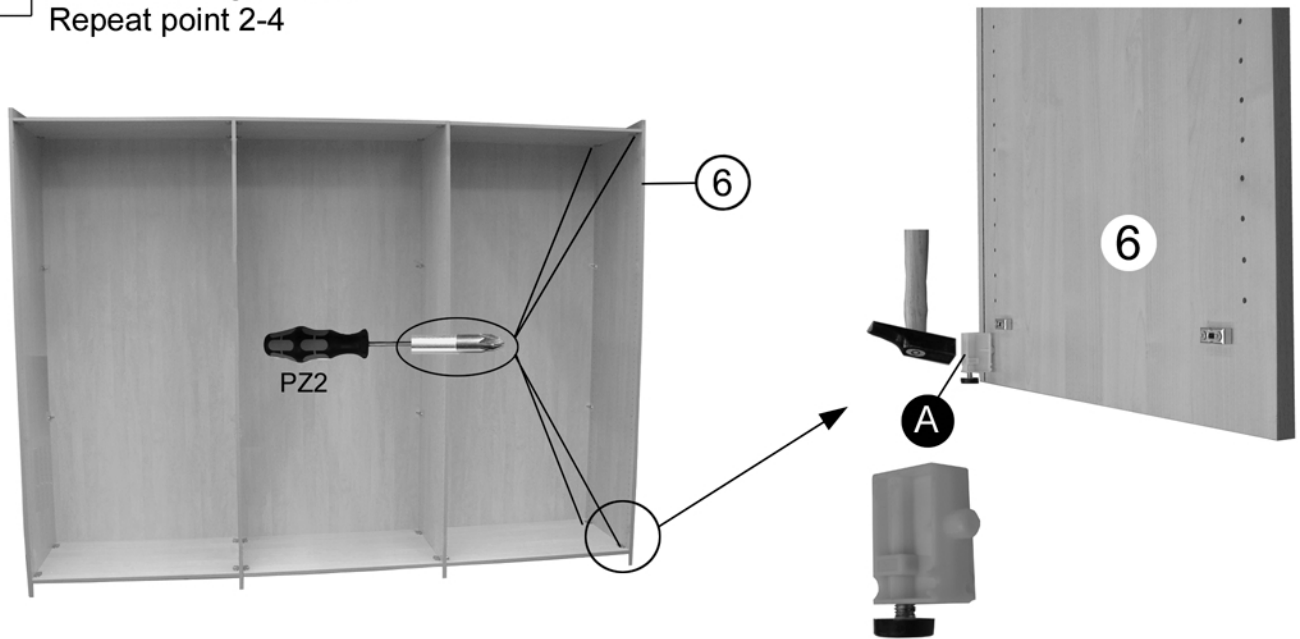

- 6.

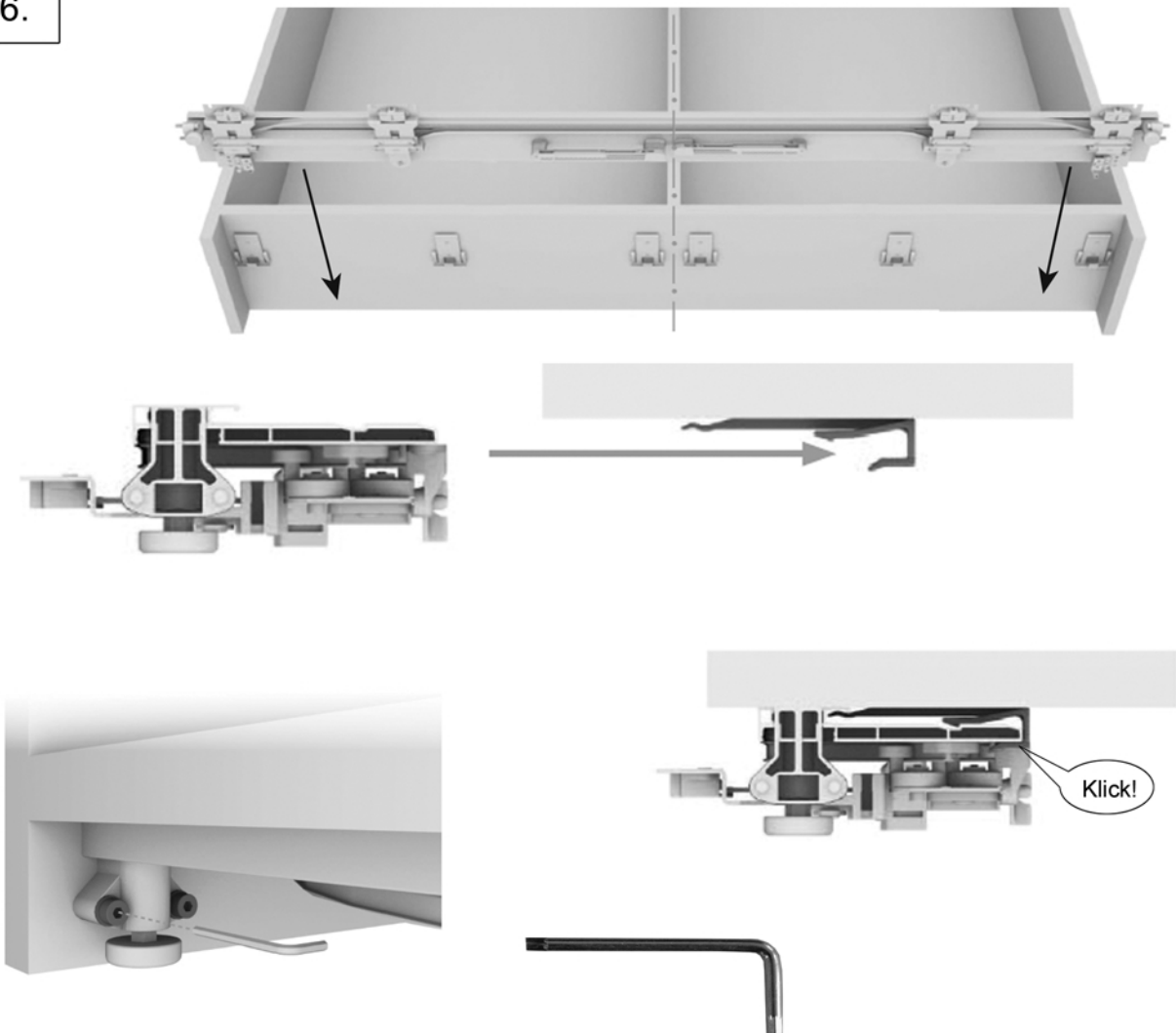

Flächenbündiger Schiebetürenschrank / Flashed sliding door wardrobe

7.

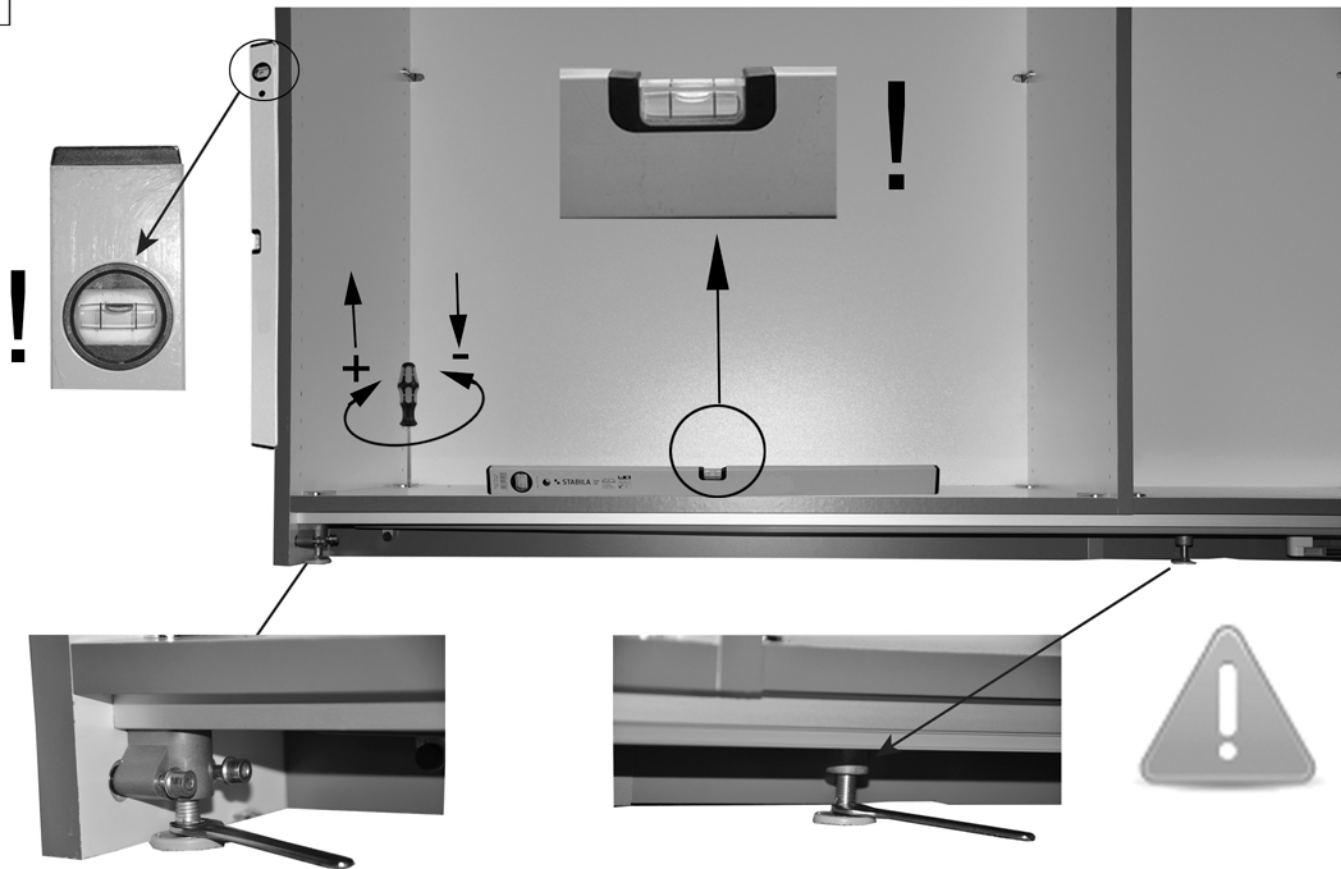

8.

Befestigungswinkel auf beide Seiten anbringen!
Fix mounting bracket on both sides!

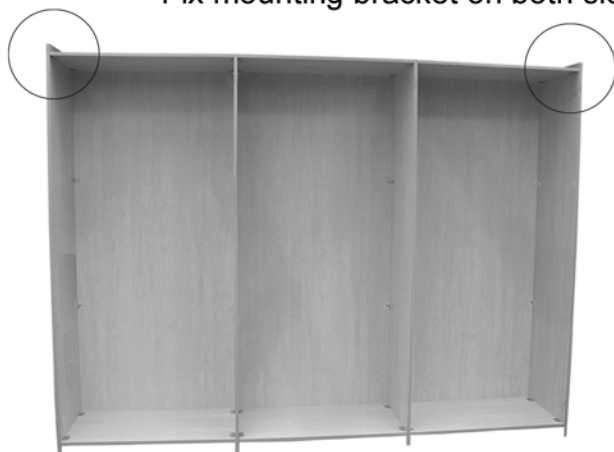

Verschraubung Wand, Dübel und 4,5x60
Screwed wall, dowel and 4.5x60

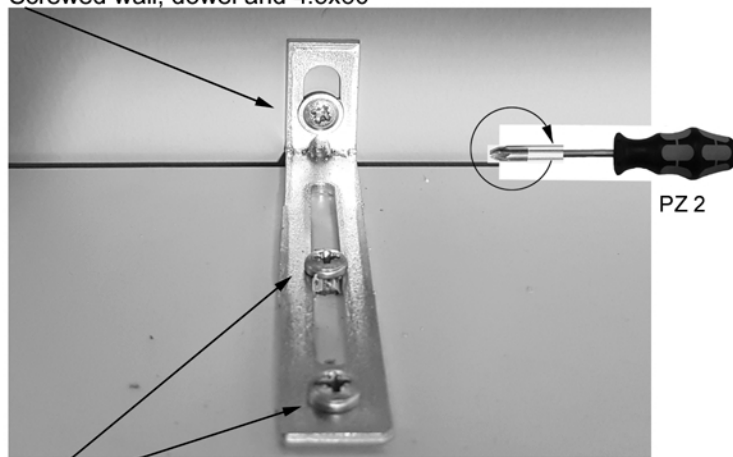

Verschraubung Deckelboden 4x20

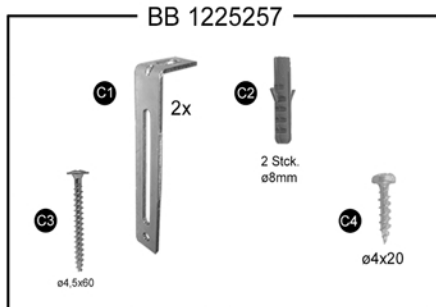

Flächenbündiger Schiebetürenschränk / Flashed sliding door wardrobe

9.

Schienenmontage oben / assembly rails above

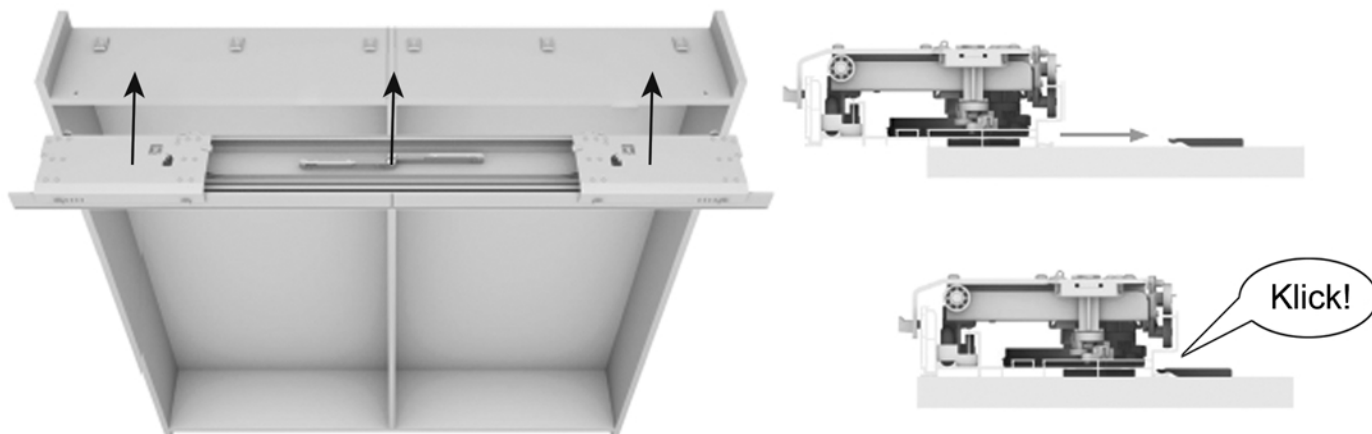

10.

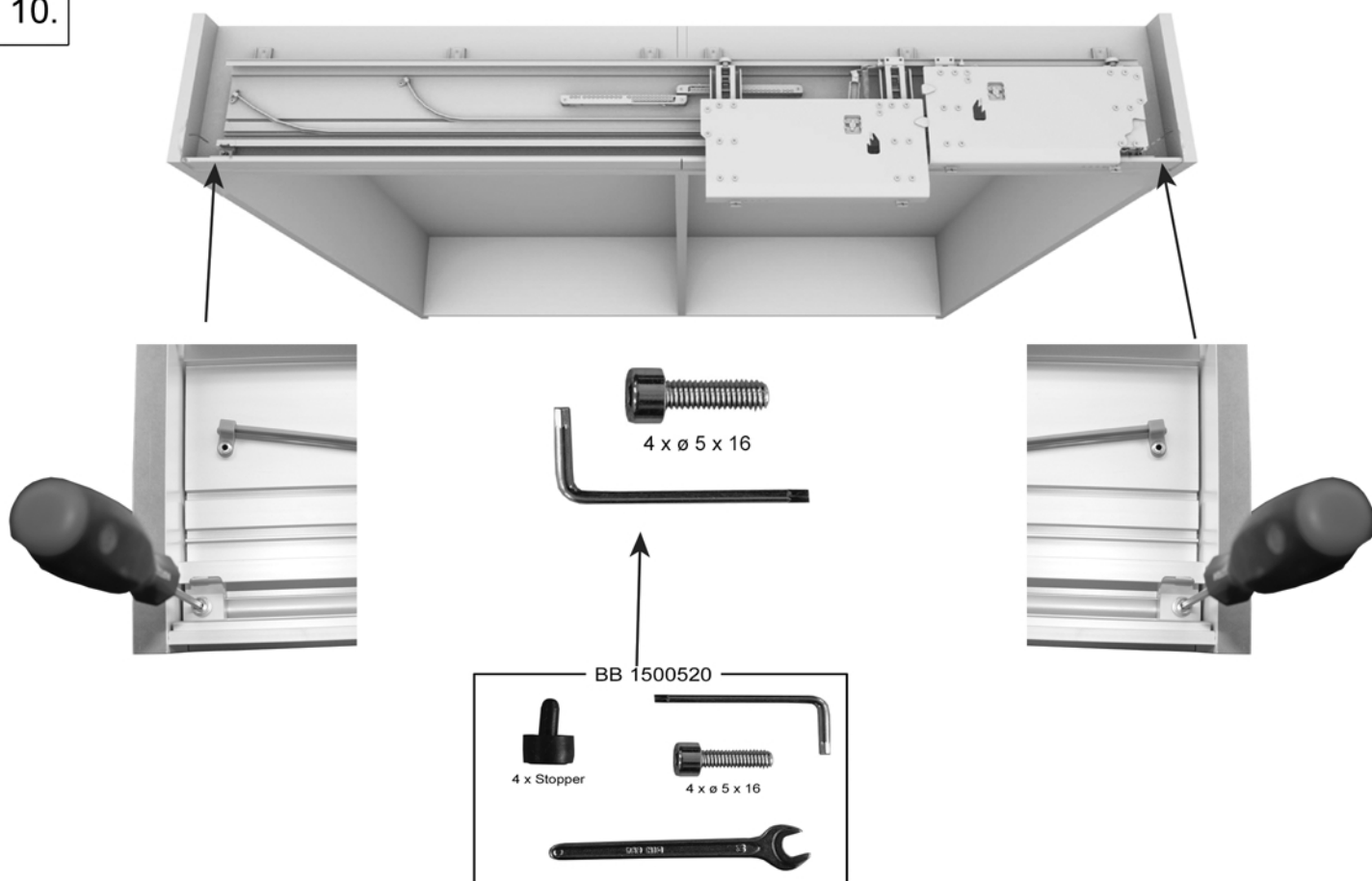

Flächenbündiger Schiebetürenschränk / Flashed sliding door wardrobe

11.

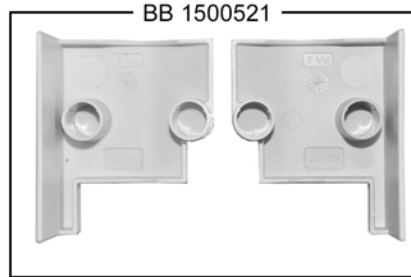
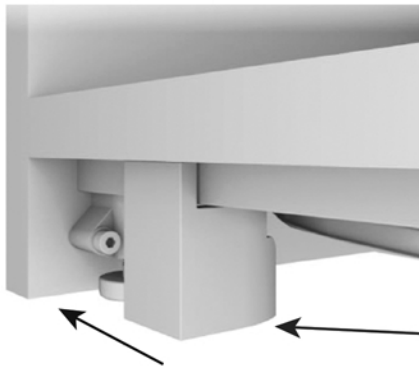

12.

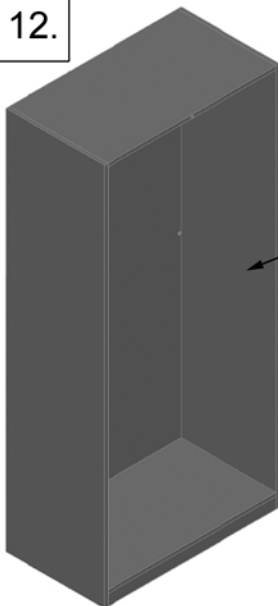

Bodenträger in gewünschter Höhe einsetzen
Use floor support at the desired height

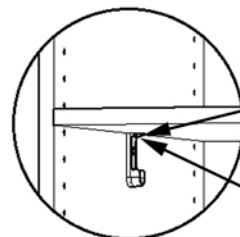
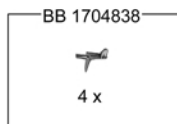
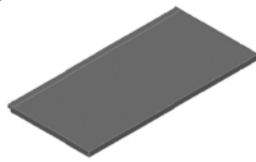

BB 1156135



(4x) \varnothing 4x30 mm

Verbindung nach oben
Connection up
4 x 30

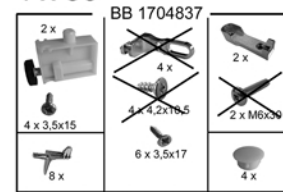
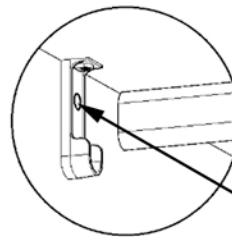

Verbindung seitlich
Lateral connection
3,5 x 17

13.

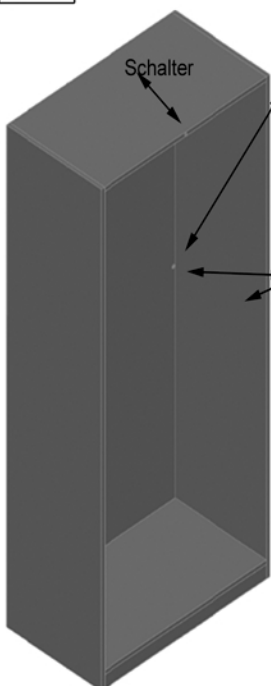

Bodenträger in gewünschter Höhe einsetzen
und in passender Höhe für die Kabeldurchführung
die Rückwand mit einer 8 mm Bohrung versehen.
Use floor support at the desired height
and at a suitable height for cable routing
the rear wall is provided with an 8 mm bore

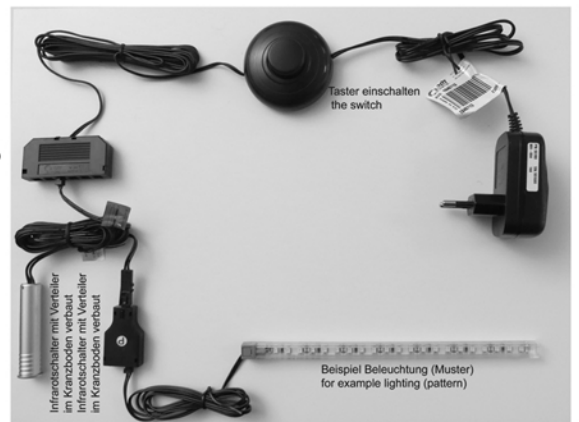
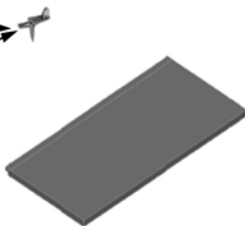

Kabel bitte oben auf den Schrank führen und dort
mit dem Kabel vom Infrarotschalter verbinden
Please lead the cable up on the cabinet and there
with the cable from the infrared switch



Flächenbündiger Schiebetürenschränk / Flashed sliding door wardrobe

14.

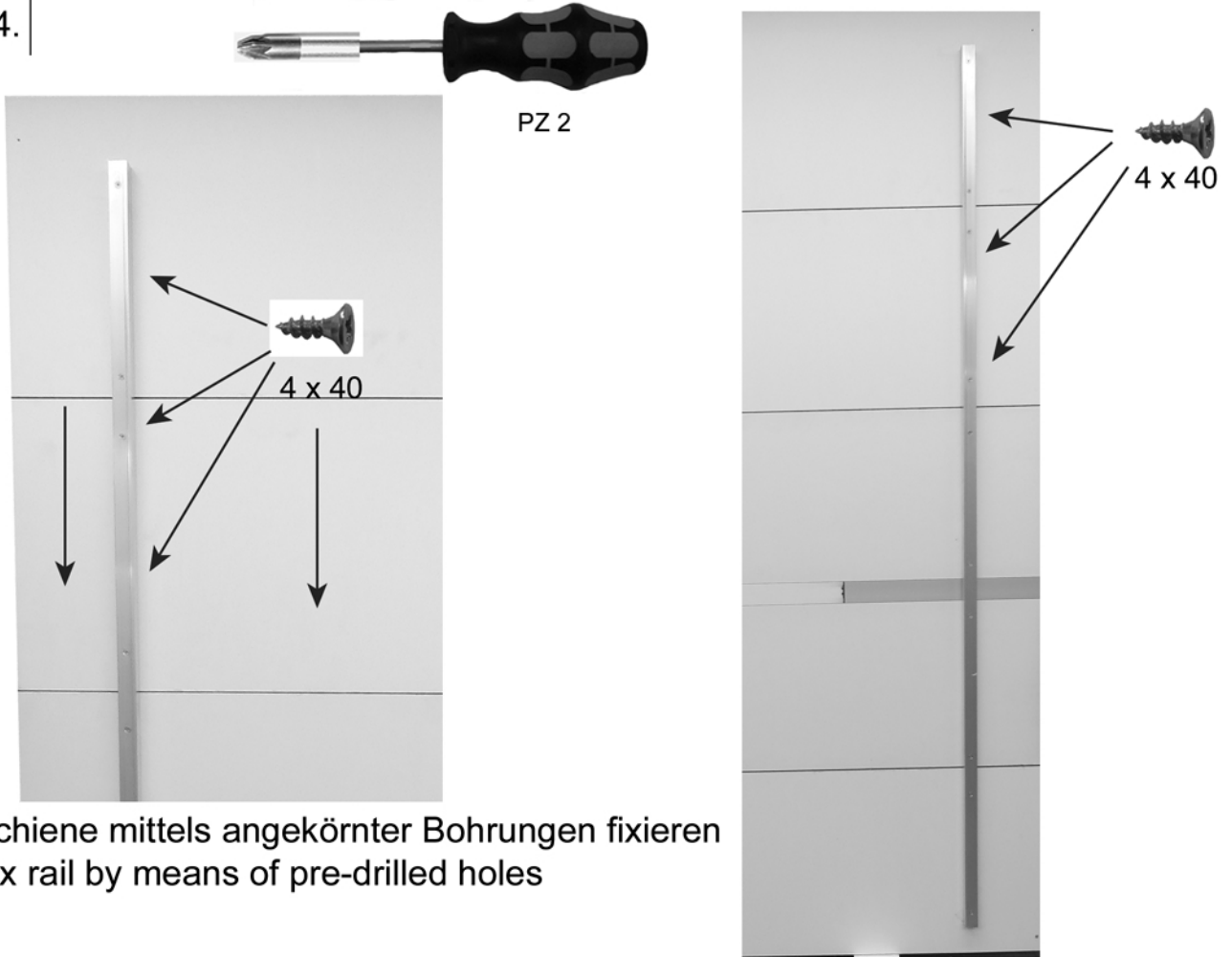

Schiene mittels angekörnter Bohrungen fixieren
Fix rail by means of pre-drilled holes

15.

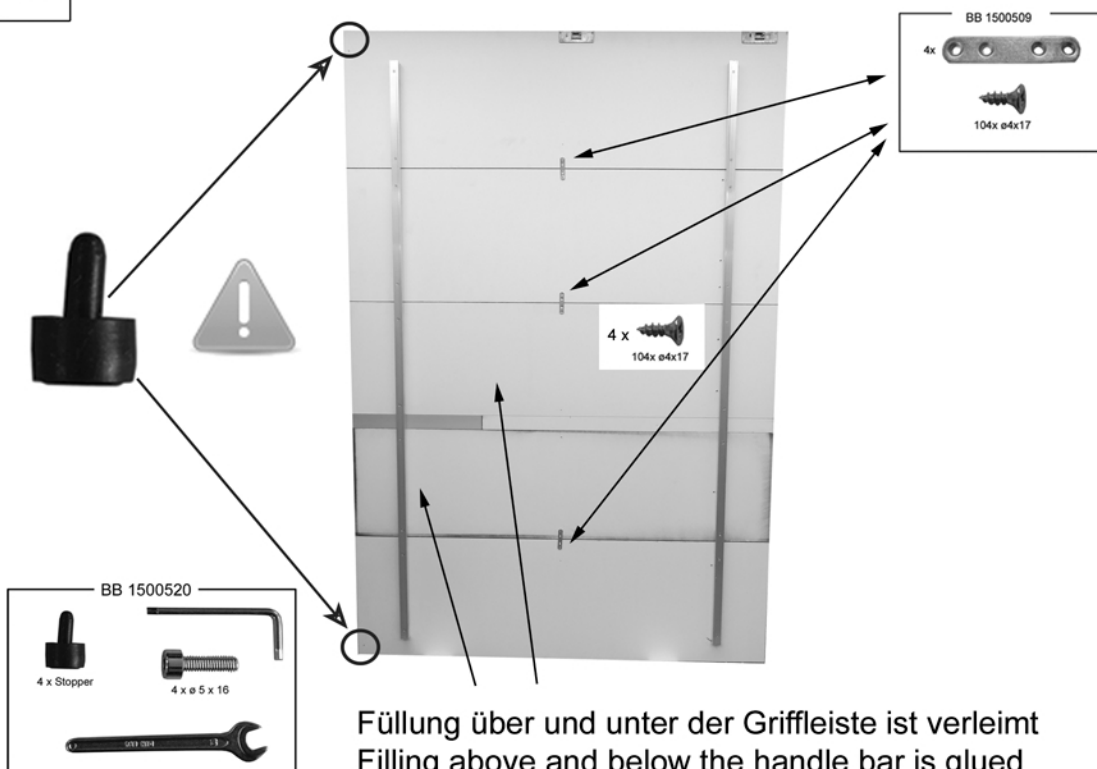

Flächenbündiger Schiebetürenschränk / Flashed sliding door wardrobe

16.

Oben / top

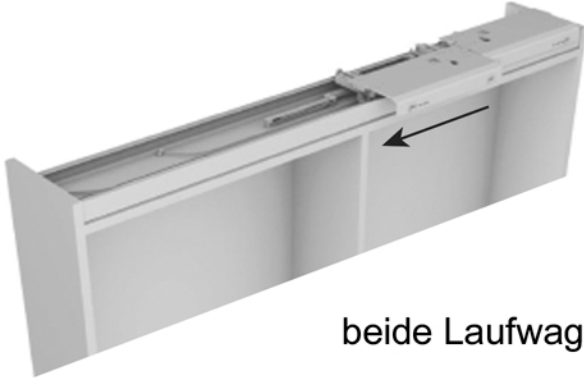

Unten / bottom

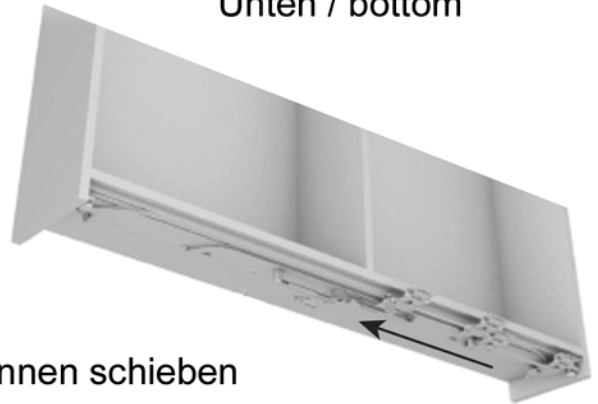

beide Laufwagen nach innen schieben
push both carriage inwards

17.

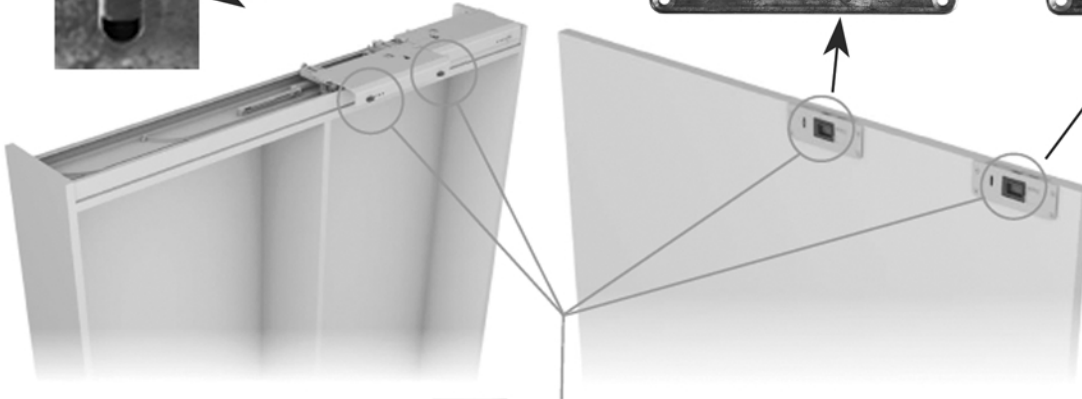
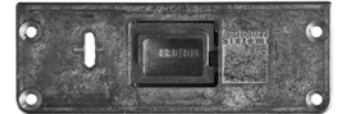
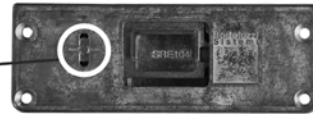
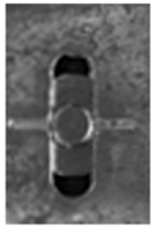

Flächenbündiger Schiebetürenschränk / Flashed sliding door wardrobe

18.

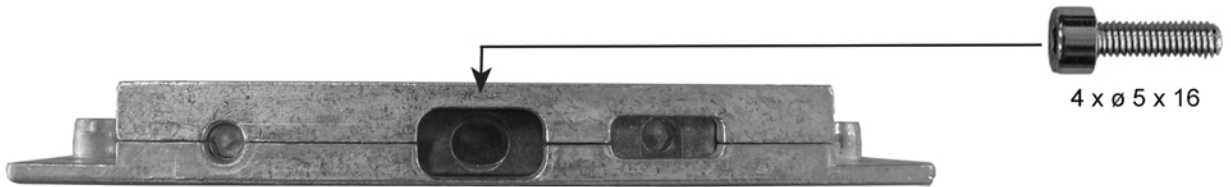
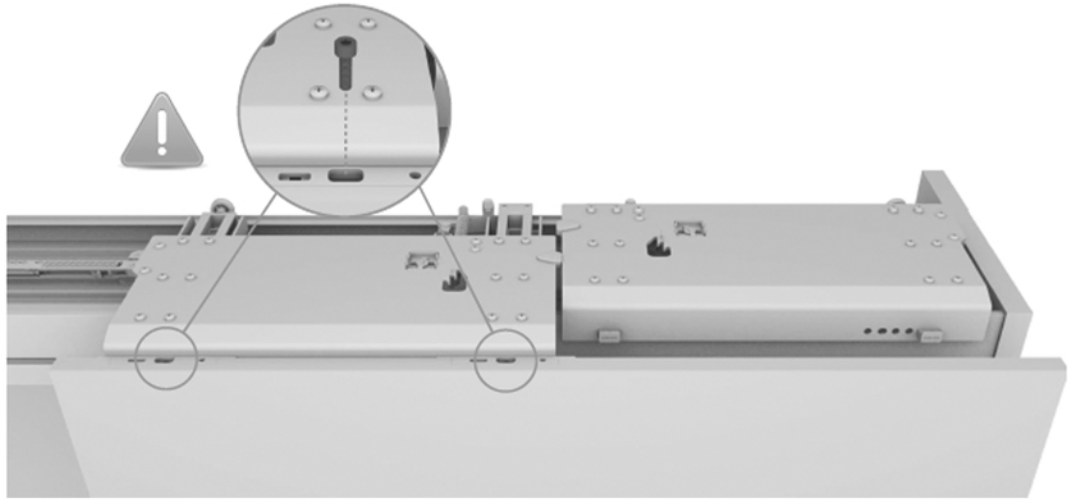

19.

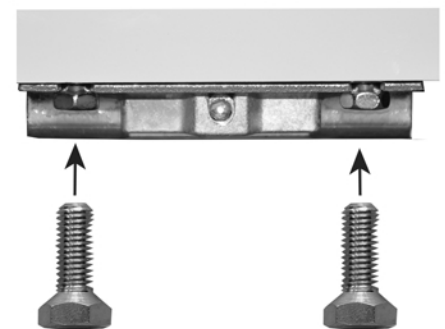
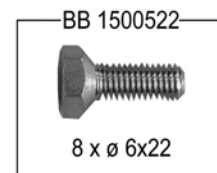

Flächenbündiger Schiebetürenschränk / Flashed sliding door wardrobe

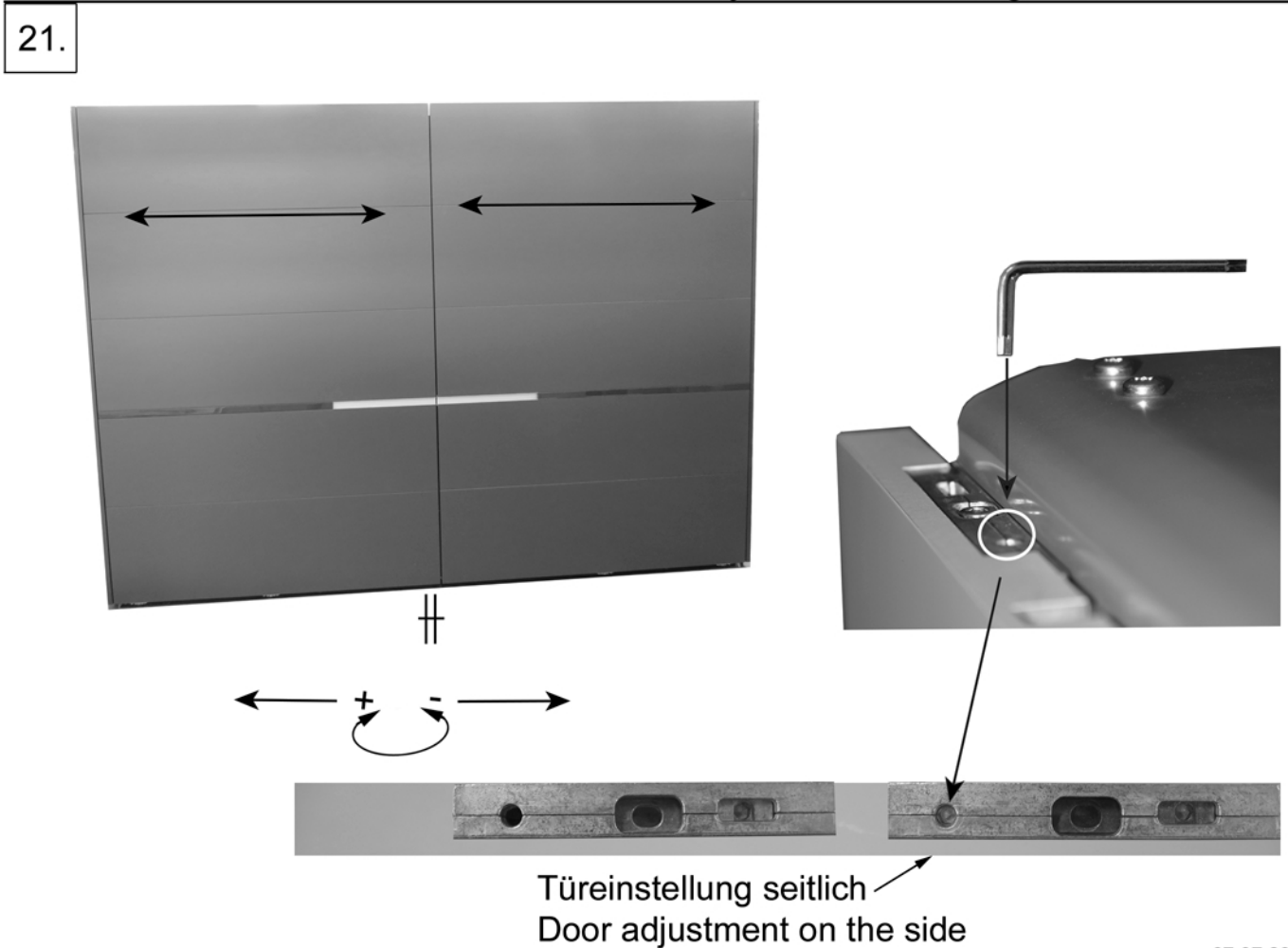
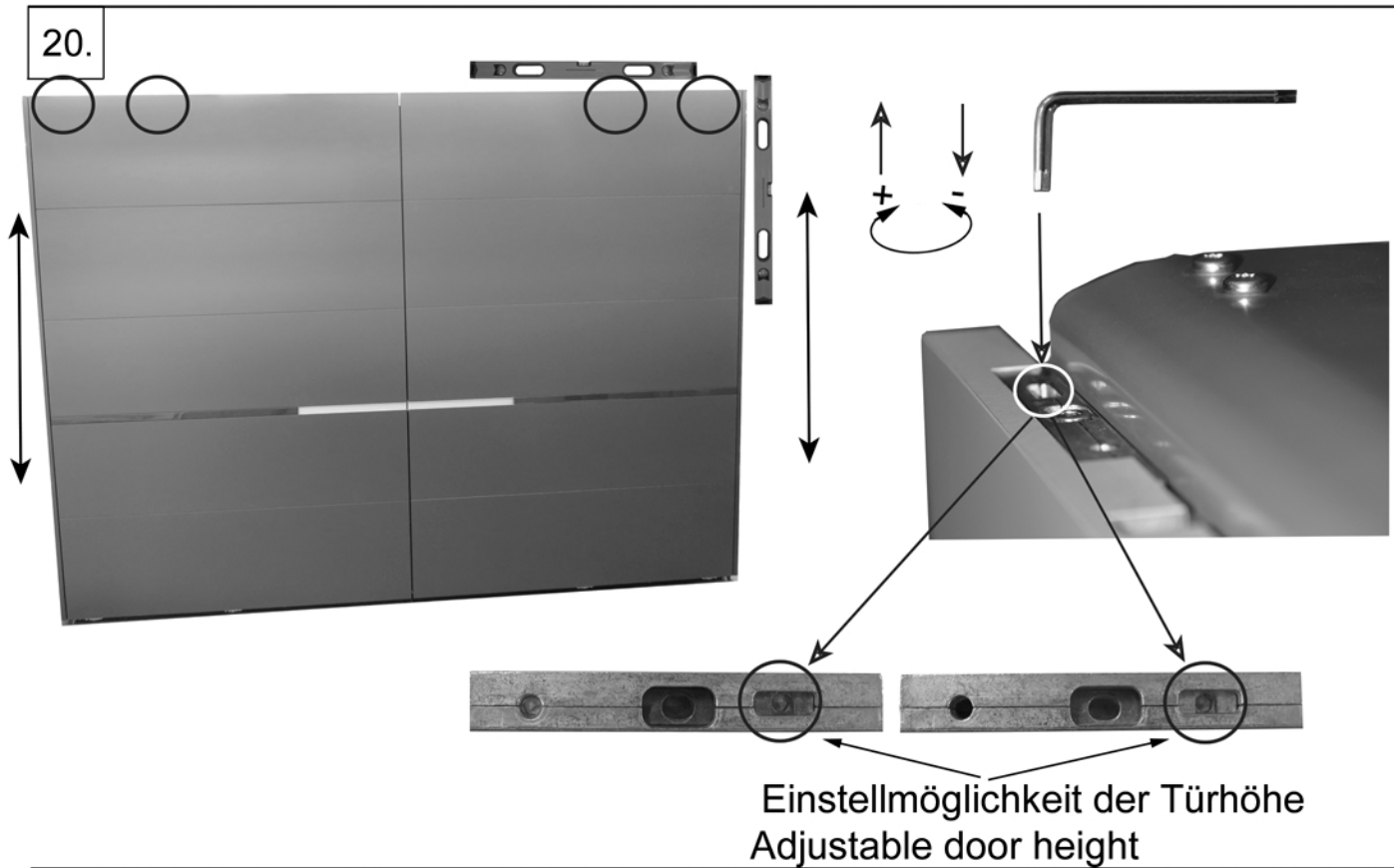

Flächenbündiger Schiebetürenschränk / Flashed sliding door wardrobe

22.

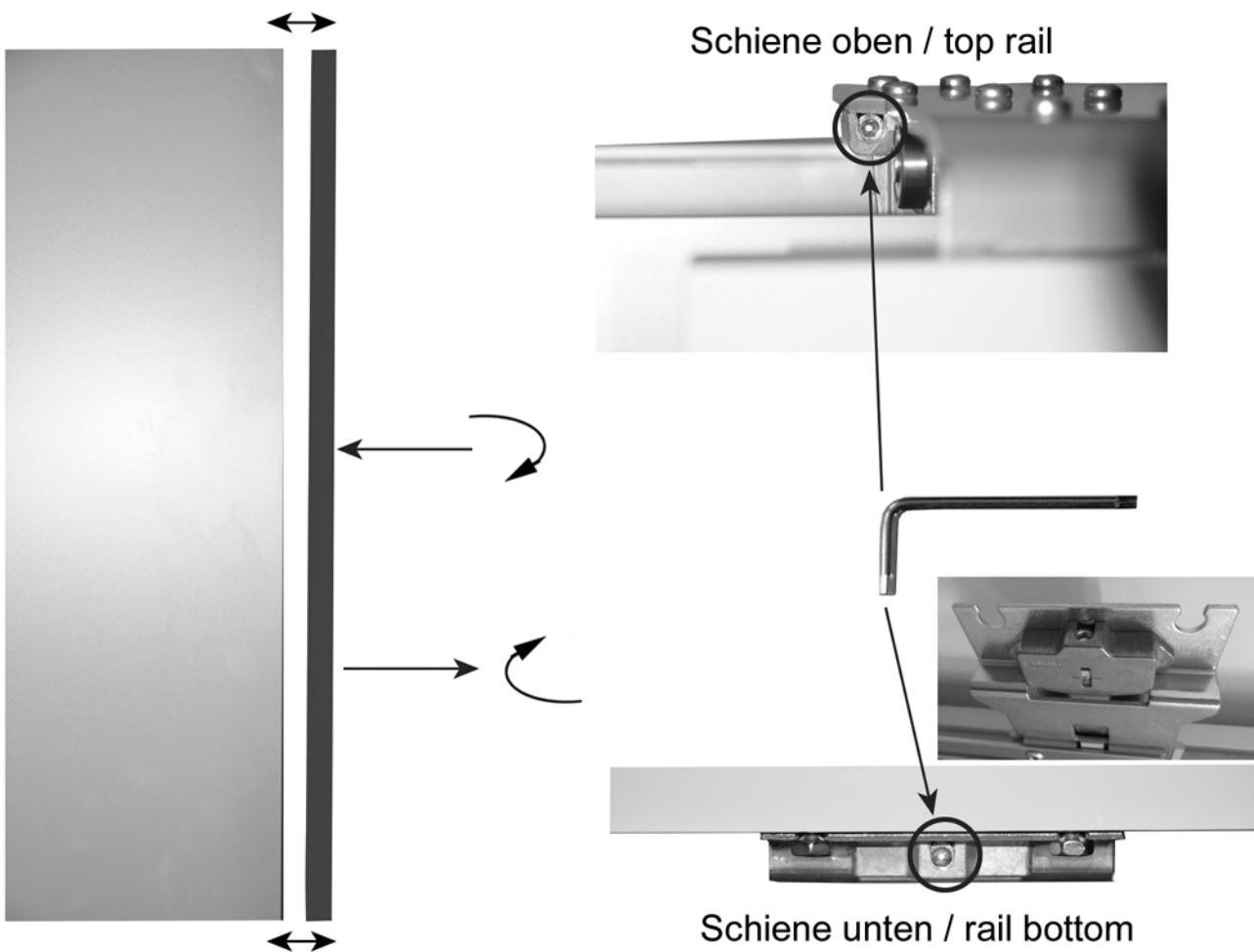

23.

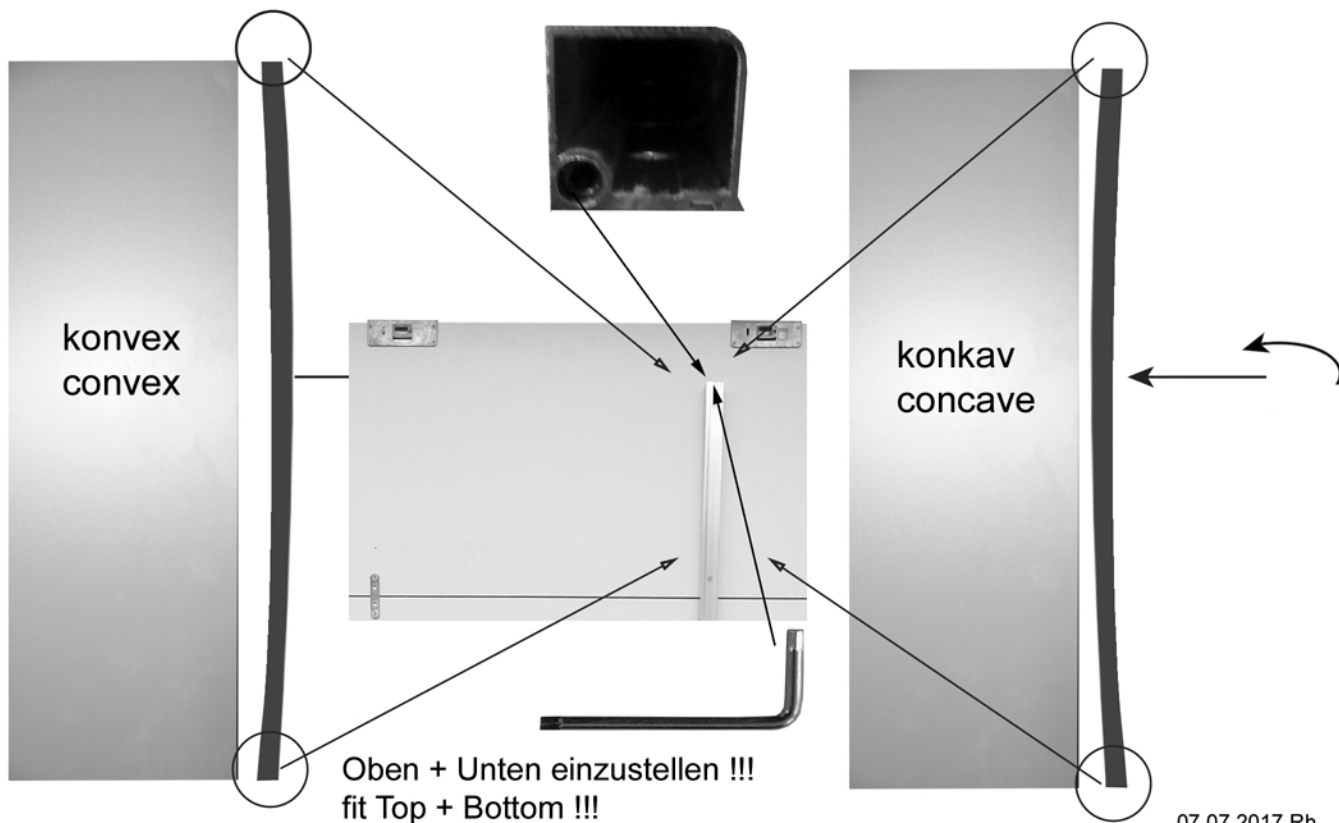

Flächenbündiger Schiebetürenschränk / Flashed sliding door wardrobe

24.

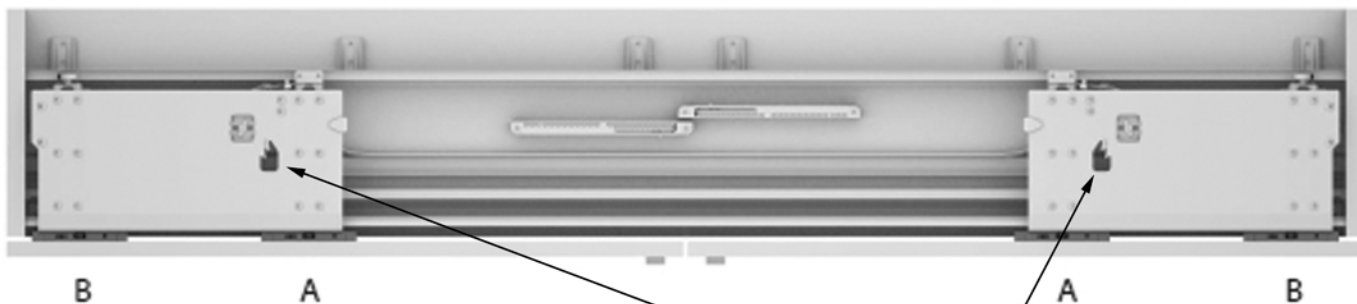

den Anschlagdruck bei großen Fronten
passen über die Feder einstellen !!!

Adjust the impact pressure for large
fronts by means of the spring

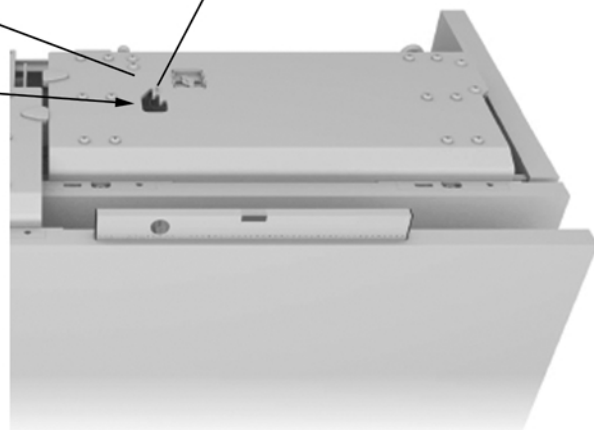

25.

Aufbauanweisung (Bitte aufbewahren)

Assembly instruction (To be kept)

Einlegeboden mit Beleuchtung / Entrances with lighting

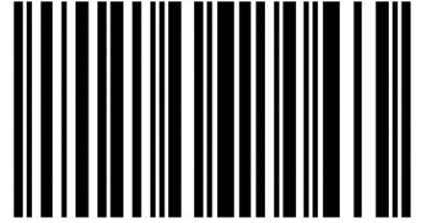

SAP 1729463



Bitte beachten Sie beim Aufbau unbedingt die Montageanweisung für Ihre neuen Möbel. Der Aufbau und die Montage dürfen ausschließlich durch autorisiertes Fachpersonal erfolgen. Bei Folgeschäden, verursacht durch eventuelle Selbstmontage oder Nichtbeachtung wichtiger Produkt- oder Montageinformationen, wird keine Haftung übernommen. Kontrollieren Sie vor der Montage, ob alle Teile vollständig und ohne Beschädigung angeliefert wurden.

Konstruktions-, Farb- und Materialänderungen im Rahmen des technischen Fortschritts bleiben uns als Lieferant vorbehalten.



Bitte dem Kunden übergeben.
Please hand over to the customer.

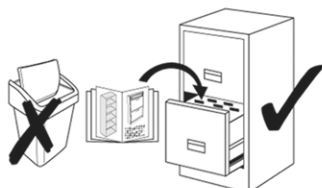

Erforderliches Aufbaupersonal:
Personel required for assembly:



Montage des Einlegeboden mit Beleuchtung
Installation of the Entrances with lighting

bitte beachten, vor Montage der Schrankelemente mit dem Kunden klären wo Bel. E.-Böden gewünscht werden, dort bitte einen Kranzboden mit dem Infraritschalter vorsehen.
Please note, before assembling the barrier elements with the customer where Bel. E. floors please provide a circling ground with the infrared switch

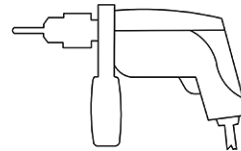
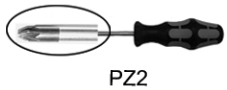

Beiliegendes Material :
Enclosed material :



mit EVG verbinden
with ECG

Kabel von der Beleuchtung anschließen
connect the cable from the lighting

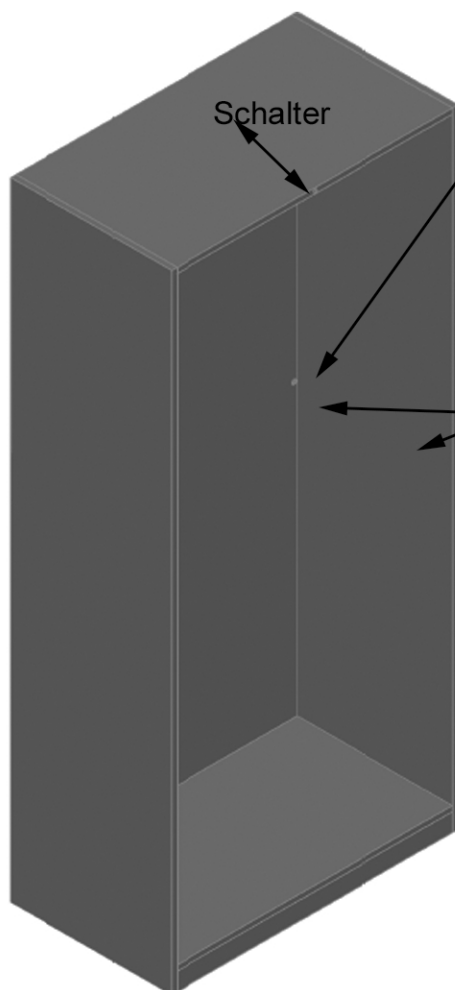
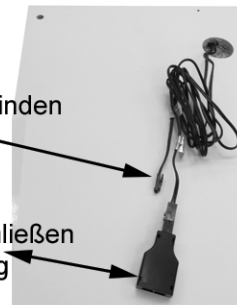

Bodenträger in gewünschter Höhe einsetzen und in passender Höhe für die Kabeldurchführung die Rückwand mit einer 8 mm Bohrung versehen.
Use floor support at the desired height and at a suitable height for cable routing the rear wall is provided with an 8 mm bore

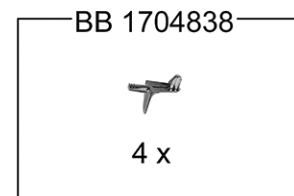
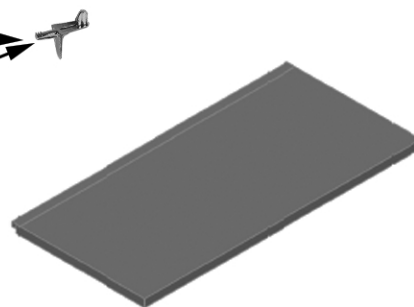

Kabel bitte oben auf den Schrank führen und dort mit dem Kabel vom Infrarotschalter verbinden
Please lead the cable up on the cabinet and there with the cable from the infrared switch

**Kranzboden m. Infrarot-Schalter ist zusätzlich, den Standard-Kranzboden bitte vernichten !!
Wreath floor m. Infrared switch is additionally, please destroy the standard corrugated floor !!**

Aufbauanweisung (Bitte aufbewahren)

Assembly instruction (To be kept)

Schranktür mit LED / Cabinet door with LED



SAP 1729464



Bitte beachten Sie beim Aufbau unbedingt die Montageanweisung für Ihre neuen Möbel. Der Aufbau und die Montage dürfen ausschließlich durch autorisiertes Fachpersonal erfolgen. Bei Folgeschäden, verursacht durch eventuelle Selbstmontage oder Nichtbeachtung wichtiger Produkt- oder Montageinformationen, wird keine Haftung übernommen. Kontrollieren Sie vor der Montage, ob alle Teile vollständig und ohne Beschädigung angeliefert wurden.

Konstruktions-, Farb- und Materialänderungen im Rahmen des technischen Fortschritts bleiben uns als Lieferant vorbehalten.



Bitte dem Kunden übergeben.
Please hand over to the customer.

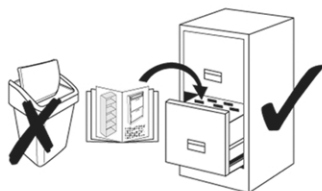

Erforderliches Aufbaupersonal:
Personel required for assembly:

Achtung bitte vor der Montage prüfen, in welchem Element eine Türbeleuchtung vorgesehen ist ??? bitte auch mit dem Kunden klären. es sind immer nur re. Türen mit einer Innenbeleuchtung lieferbar.

Door lighting is provided ??? Please also clarify with the customer. Please check before installation, in which element a There are always only re. Doors with interior lighting available.

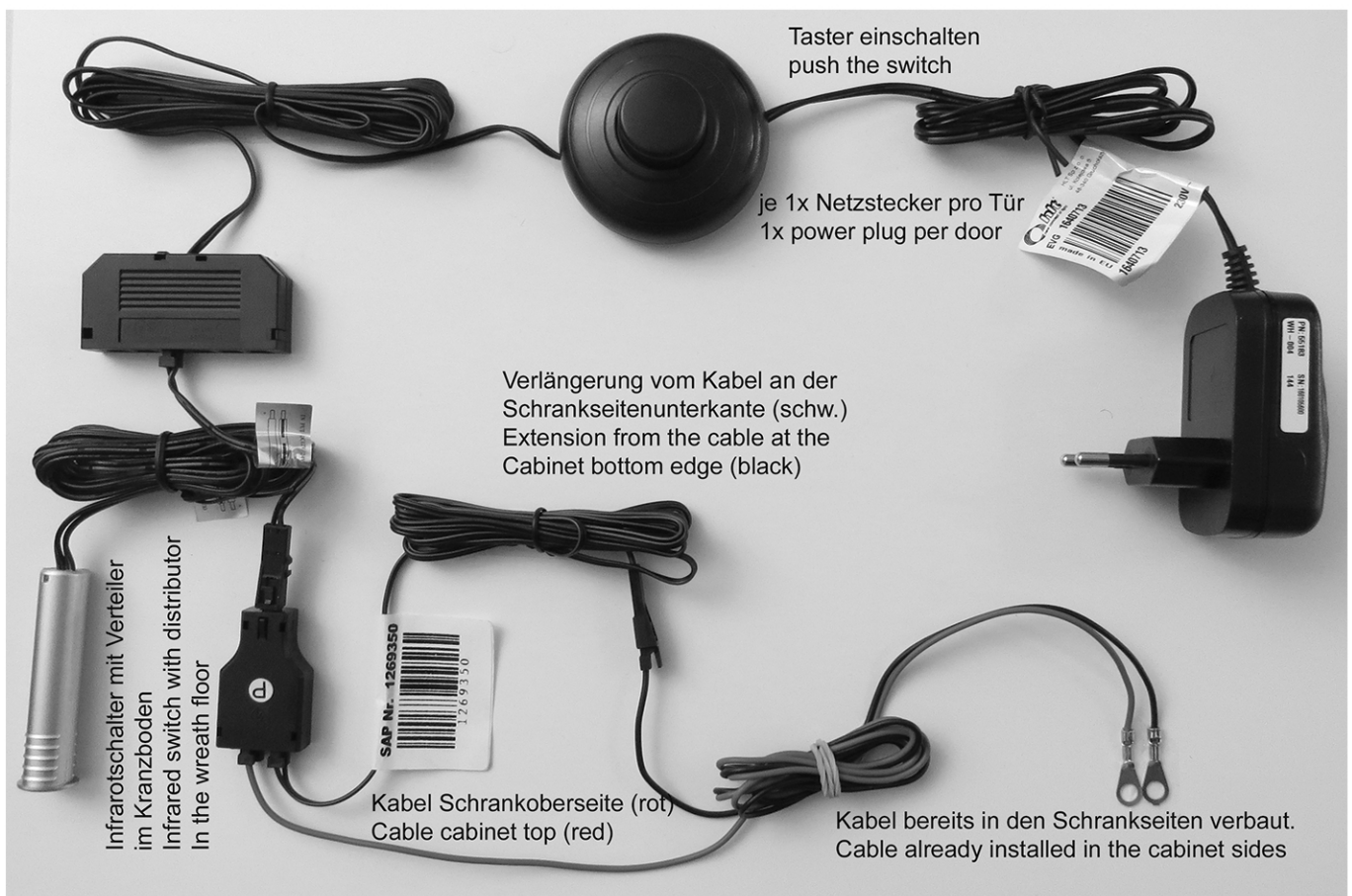

Kontakt erhält die Tür über das obere + untere Topfband hier wird der Strom über die Kreuzmontageplatten an die Tür weitergegeben
 Contact gets the door over the top + bottom pot band
 Here the current is passed on to the door via the cross-mounting plates

die Kreuzmontageplatten erhalten über ein Kabel den erforderlichen Strom
 Kabel ist in der re. Seite verbaut und muss mit dem EVG verbunden werden
 oben mit dem Roten unten mit dem Schwarzen Kabel (Unten zus.m.Verlängerung)
 the cross-mounting plates receive the required current via a cable
 Cable is in the re. Side and must be connected to the ECG
 Up with the red down with the black cable (down to extension)

Aufbauanweisung (Bitte aufbewahren)

Assembly instruction (To be kept)

Montageanweisung Schubkasteneinsatz / Installation instructions

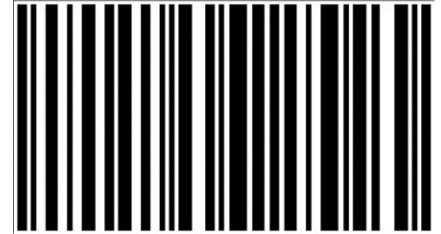

SAP 1729465



Bitte beachten Sie beim Aufbau unbedingt die Montageanweisung für Ihre neuen Möbel. Der Aufbau und die Montage dürfen ausschließlich durch autorisiertes Fachpersonal erfolgen. Bei Folgeschäden, verursacht durch eventuelle Selbstmontage oder Nichtbeachtung wichtiger Produkt- oder Montageinformationen, wird keine Haftung übernommen. Kontrollieren Sie vor der Montage, ob alle Teile vollständig und ohne Beschädigung angeliefert wurden.

Konstruktions-, Farb- und Materialänderungen im Rahmen des technischen Fortschritts bleiben uns als Lieferant vorbehalten.



Bitte dem Kunden übergeben.
Please hand over to the customer.

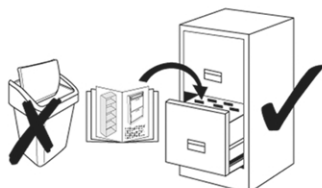

Erforderliches Aufbaupersonal:
Personel required for assembly:



PZ2

Montage der Schubkasteneinsätze Fitting the drawer inserts

Beiliegendes Material :
Enclosed material :

BB 1704838



4 x

BB 1437178



4 x 70

Montage auf dem Sockelboden / Mounting on the base of the base

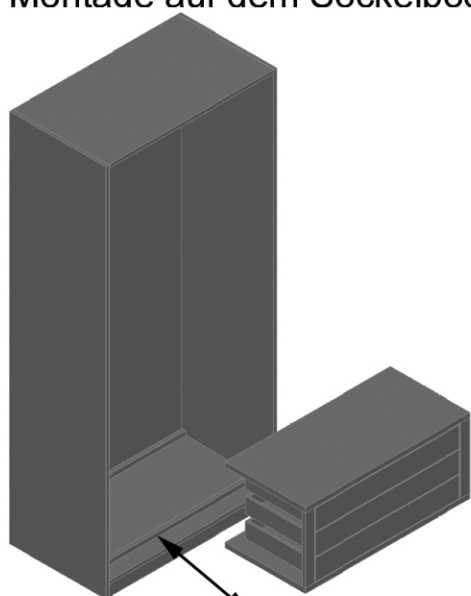

Montageleisten plazieren
Place the mounting strips

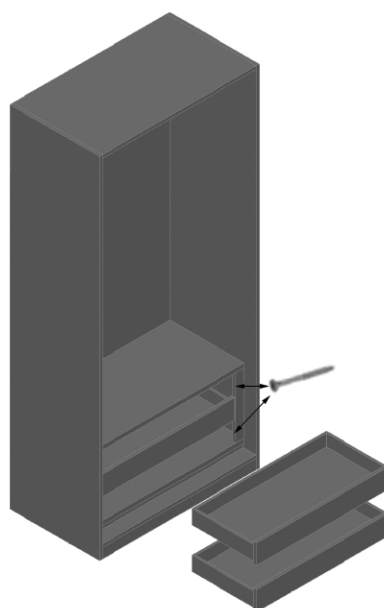

Einsatz einsetzen
und seitlich verschrauben
Insert the insert
And screw it to the side



PZ2

BB 1437178



4 x 70

Montage in gewünschter Höhe auf Bodenträger Mounting at the desired height on floor supports

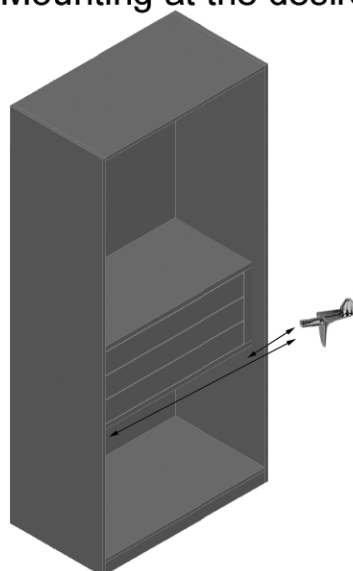

Bodenträger plazieren und Einsatz einschieben
Place the carrier and insert the insert

BB 1704838



4 x

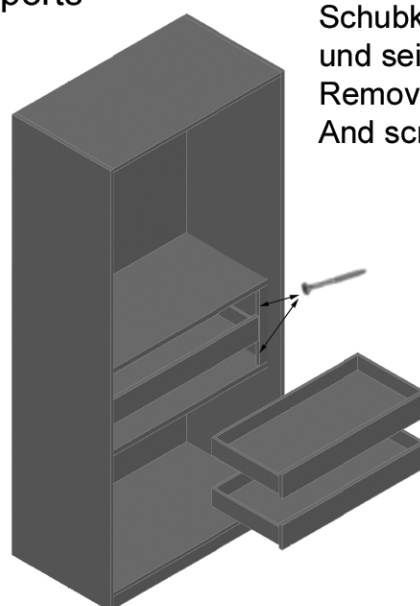

Schubkästen entfernen
und seitlich verschrauben
Remove the drawer
And screw it to the side



PZ2

BB 1437178



4 x 70

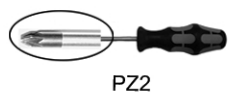

Montage der Schubkasteneinsätze
Fitting the drawer inserts

Beiliegendes Material :
Enclosed material :

BB 1704838



4 x

BB 1437178



4 x 70

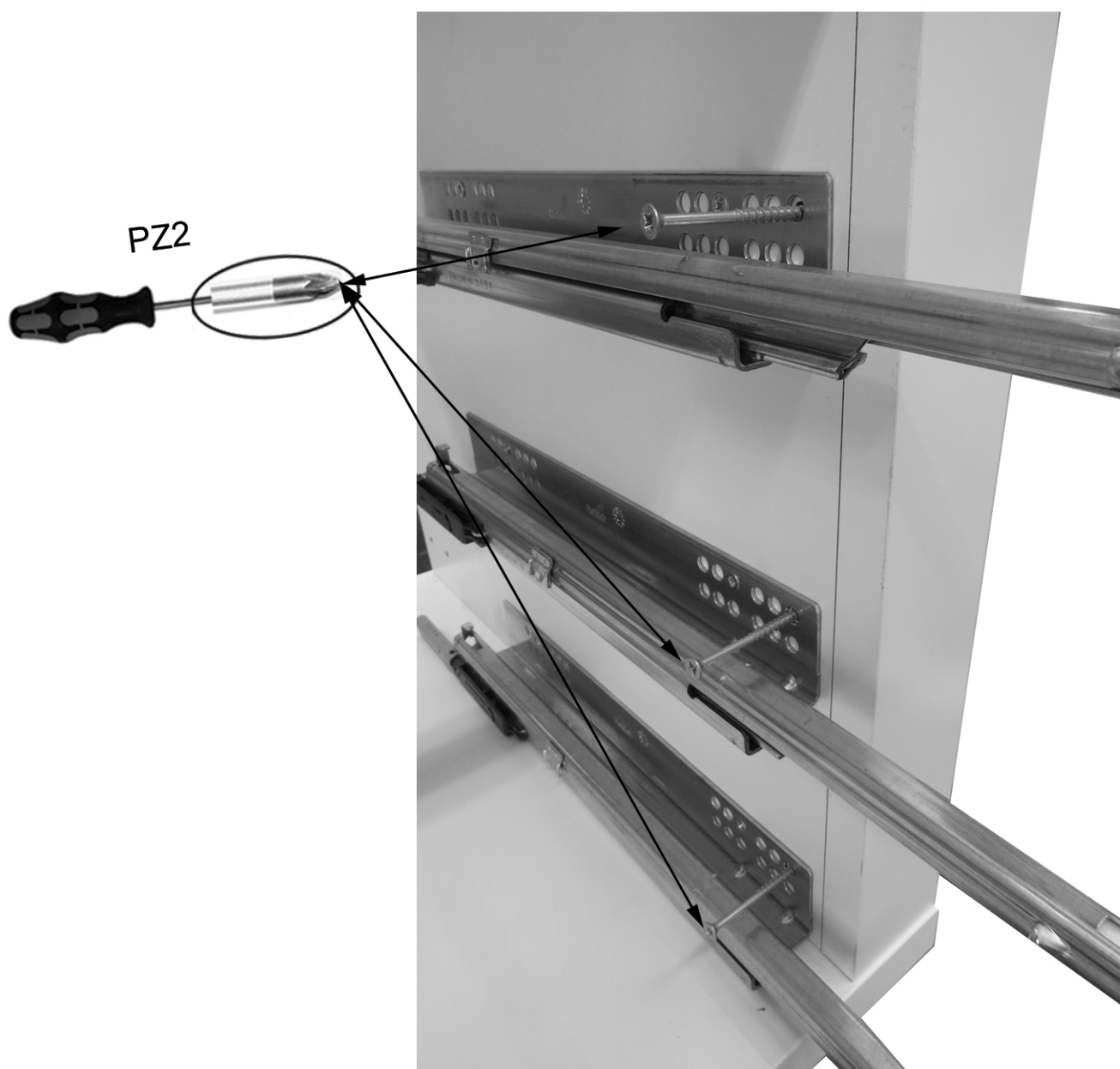

Aufbauanweisung (Bitte aufbewahren)

Assembly instruction (To be kept)

Montageanweisung Hosenhalter / Mounting instructions Hose hanger

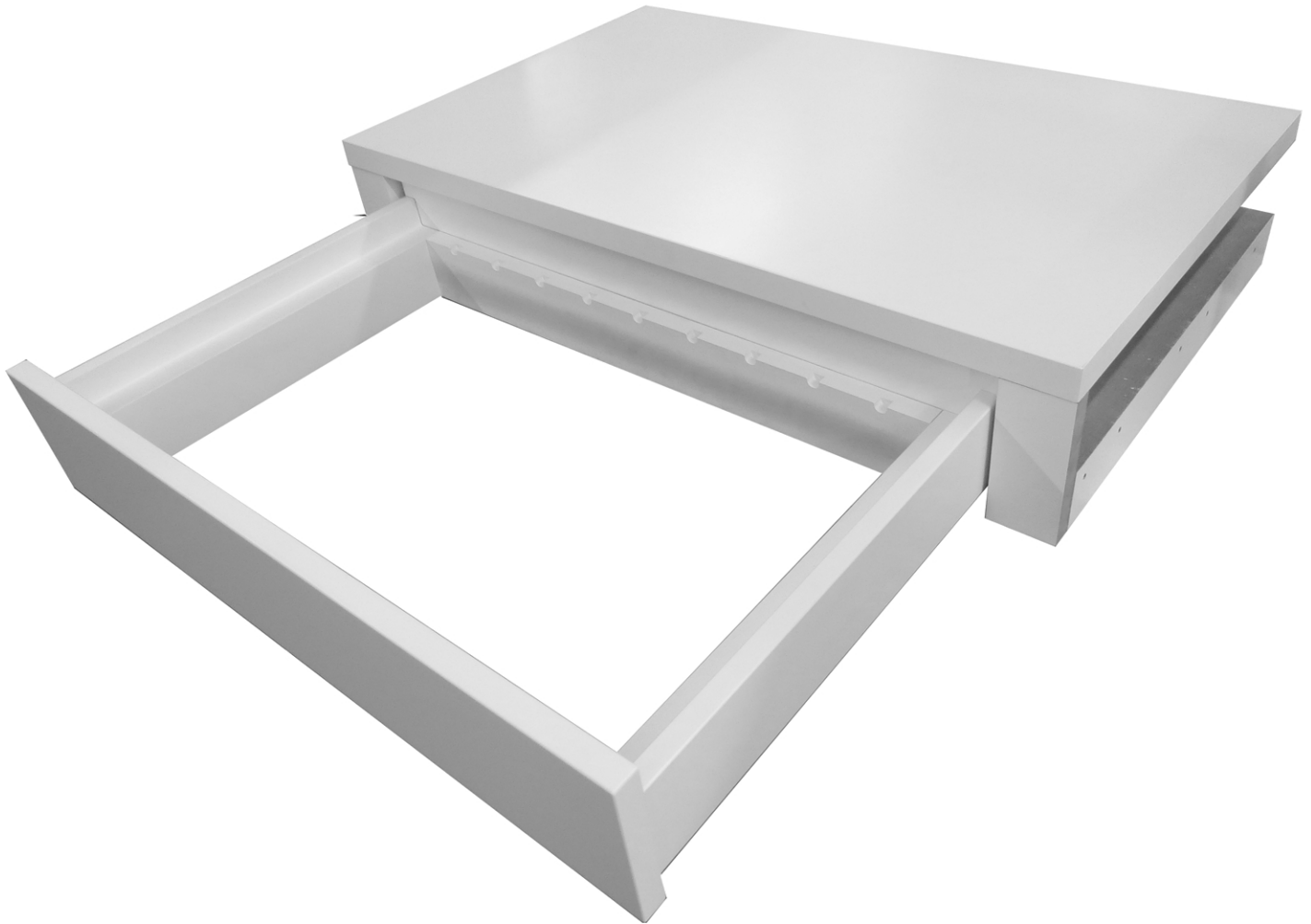

Bitte beachten Sie beim Aufbau unbedingt die Montageanweisung für Ihre neuen Möbel. Der Aufbau und die Montage dürfen ausschließlich durch autorisiertes Fachpersonal erfolgen. Bei Folgeschäden, verursacht durch eventuelle Selbstmontage oder Nichtbeachtung wichtiger Produkt- oder Montageinformationen, wird keine Haftung übernommen. Kontrollieren Sie vor der Montage, ob alle Teile vollständig und ohne Beschädigung angeliefert wurden.

Konstruktions-, Farb- und Materialänderungen im Rahmen des technischen Fortschritts bleiben uns als Lieferant vorbehalten.



Bitte dem Kunden übergeben.
Please hand over to the customer.

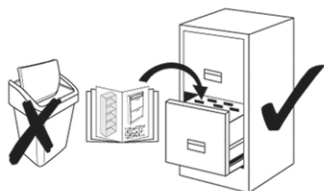

Erforderliches Aufbaupersonal:
Personel required for assembly:



PZ2

Montage vom Hosenauszug Assembly of the trousers

Beiliegendes Material :
Enclosed material :

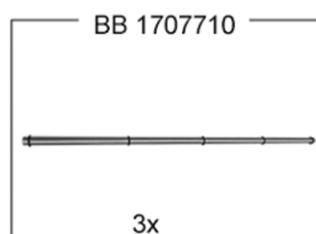
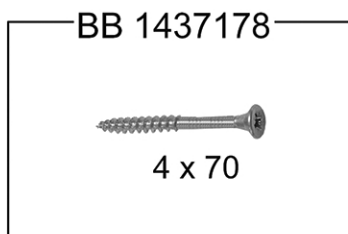

Montage vom Hosenauszug Assembly of the trousers

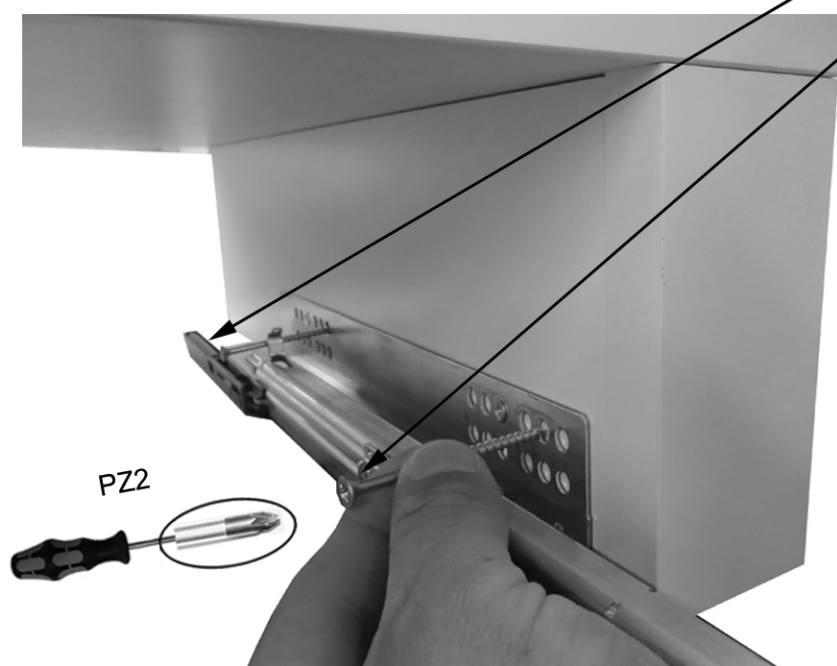
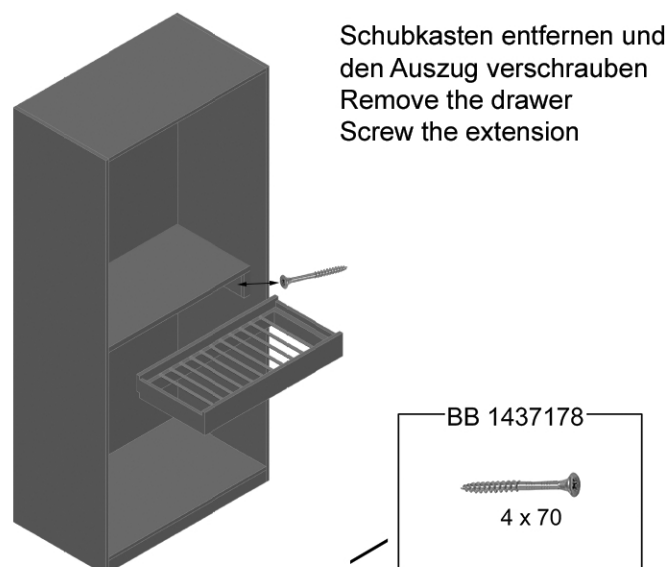
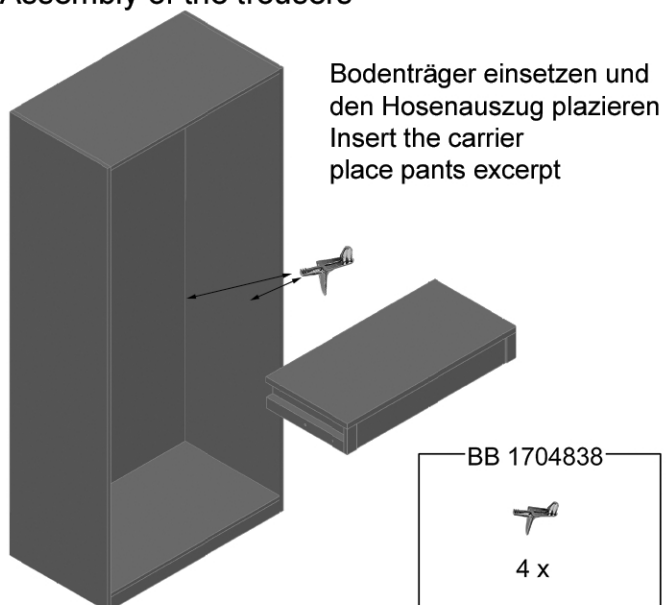

Aufbauanweisung (Bitte aufbewahren)

Assembly instruction (To be kept)

Montageanweisung Hemdenbrücke / Installation instruction shirts bridge

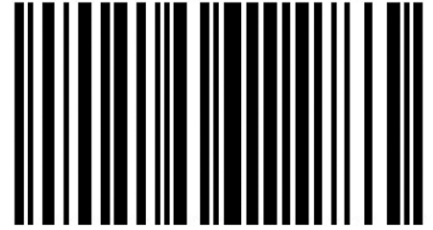

SAP 1729467



Bitte beachten Sie beim Aufbau unbedingt die Montageanweisung für Ihre neuen Möbel. Der Aufbau und die Montage dürfen ausschließlich durch autorisiertes Fachpersonal erfolgen. Bei Folgeschäden, verursacht durch eventuelle Selbstmontage oder Nichtbeachtung wichtiger Produkt- oder Montageinformationen, wird keine Haftung übernommen. Kontrollieren Sie vor der Montage, ob alle Teile vollständig und ohne Beschädigung angeliefert wurden.

Konstruktions-, Farb- und Materialänderungen im Rahmen des technischen Fortschritts bleiben uns als Lieferant vorbehalten.



Bitte dem Kunden übergeben.
 Please hand over to the customer.

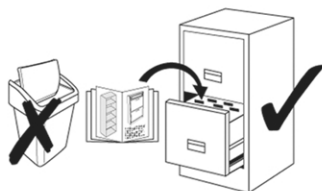

Erforderliches Aufbaupersonal:
 Personnel required for assembly:

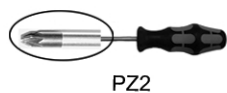

PZ2

Montage der Fachunterteilung
Fitting the drawer inserts

Beiliegendes Material :
Enclosed material :



Montage der Fachunterteilung
Assembly of the compartment

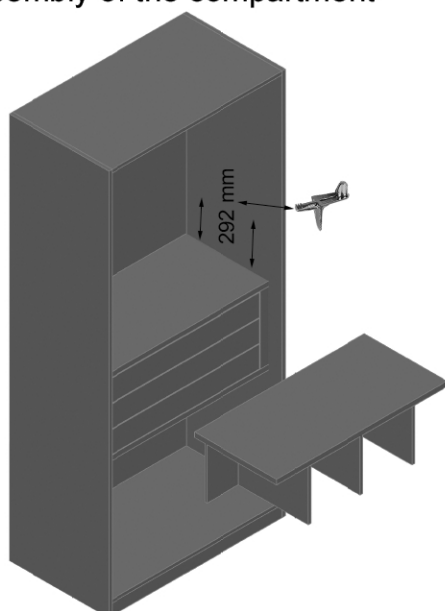

Bodenträger einsetzen
to use the funds
und Unterteilung platzieren
and subdivision

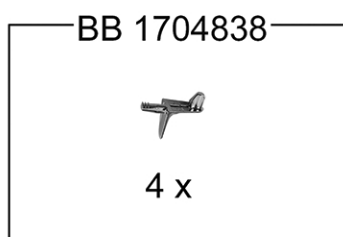

bei der niedrigen Höhe wird der Einsatz nur aufgesetzt
at the low level the bet is only placed



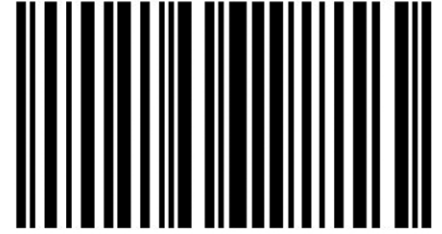

SAP 1729468



Bitte beachten Sie beim Aufbau unbedingt die Montageanweisung für Ihre neuen Möbel. Der Aufbau und die Montage dürfen ausschließlich durch autorisiertes Fachpersonal erfolgen. Bei Folgeschäden, verursacht durch eventuelle Selbstmontage oder Nichtbeachtung wichtiger Produkt- oder Montageinformationen, wird keine Haftung übernommen. Kontrollieren Sie vor der Montage, ob alle Teile vollständig und ohne Beschädigung angeliefert wurden.

Konstruktions-, Farb- und Materialänderungen im Rahmen des technischen Fortschritts bleiben uns als Lieferant vorbehalten.



Bitte dem Kunden übergeben.
Please hand over to the customer.

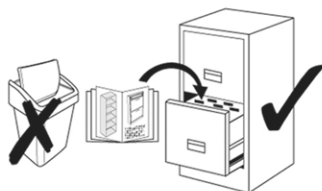

Erforderliches Aufbaupersonal:
Personel required for assembly:

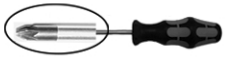

PZ2

Montageanleitung T.-Einsatz Installation instructions T.-Use

Beiliegendes Material :
Enclosed material :

BB 1710113 4 x 4 x 4,2 x 10,5 2 x	BB 1704839 8 x	BB 1156135 (4x) \varnothing 4x30 mm	BB 1078900 2 x 2 x M6x30			
BB 1704837 <table border="1"> <tr> <td data-bbox="86 656 177 792"> 2 x 4 x 3,5x15 8 x </td> <td data-bbox="177 656 284 792"> 4 x 4 x 4,2x10,5 6 x 3,5x17 </td> <td data-bbox="284 656 376 792"> 2 x 2 x M6x30 4 x </td> </tr> </table>				2 x 4 x 3,5x15 8 x	4 x 4 x 4,2x10,5 6 x 3,5x17	2 x 2 x M6x30 4 x
2 x 4 x 3,5x15 8 x	4 x 4 x 4,2x10,5 6 x 3,5x17	2 x 2 x M6x30 4 x				

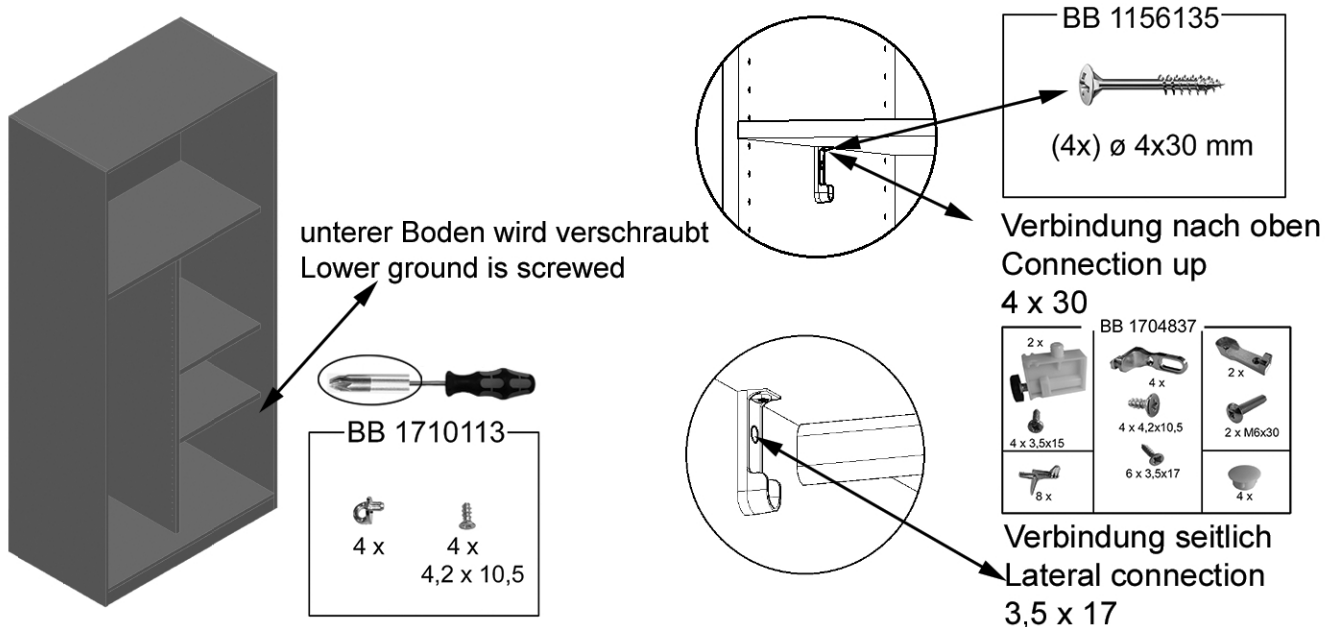
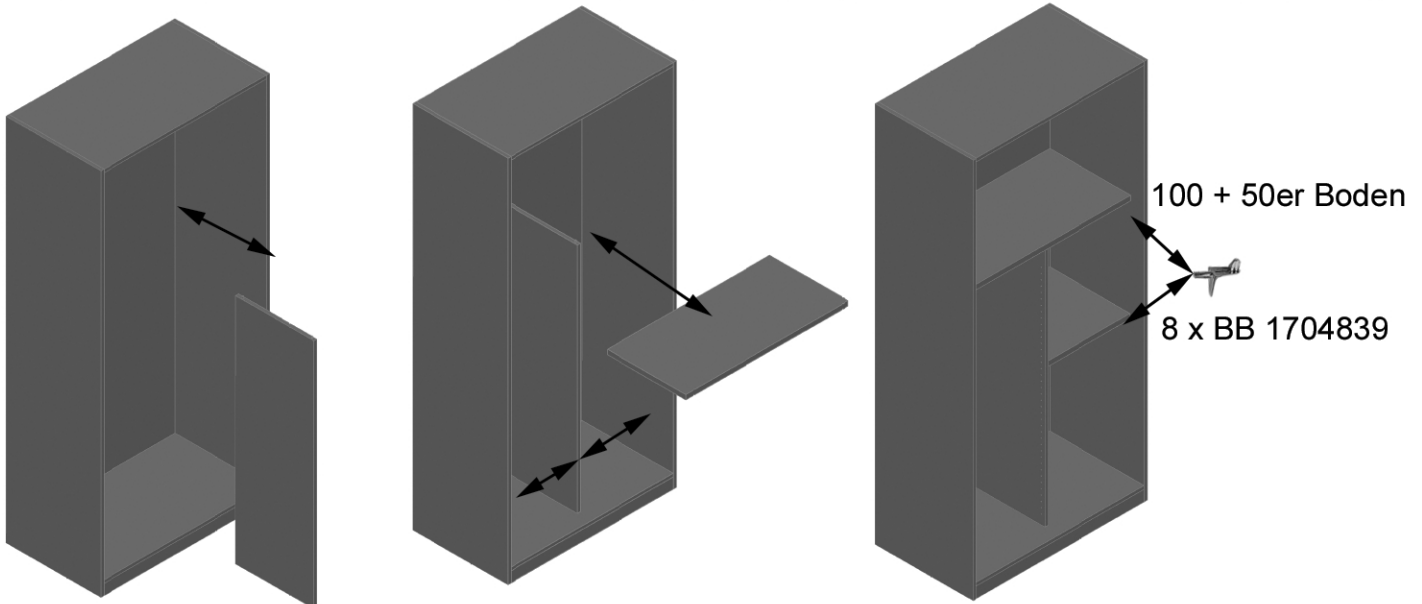



W O H N E N

Aufbauanweisung (Bitte aufbewahren)

Assembly instruction (To be kept)

Konsolen + Kommoden / Consoles + chests of drawers

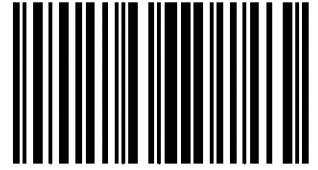

SAP 1729469



Bitte beachten Sie beim Aufbau unbedingt die Montageanweisung für Ihre neuen Möbel. Der Aufbau und die Montage dürfen ausschließlich durch autorisiertes Fachpersonal erfolgen. Bei Folgeschäden, verursacht durch eventuelle Selbstmontage oder Nichtbeachtung wichtiger Produkt- oder Montageinformationen, wird keine Haftung übernommen. Kontrollieren Sie vor der Montage, ob alle Teile vollständig und ohne Beschädigung angeliefert wurden.

Konstruktions-, Farb- und Materialänderungen im Rahmen des technischen Fortschritts bleiben uns als Lieferant vorbehalten.



Bitte dem Kunden übergeben.
Please hand over to the customer.

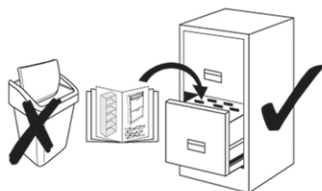

Erforderliches Aufbaupersonal:
Personel required for assembly:

04.07.2017 Rh.

Konsolen + Kommoden / Consoles + chests of drawers

Artikelnummern		
----------------	--	--



∅ 5 mm Holzbohrer/ Wood drill

∅ 6 mm Steinbohrer/ Stone drill



Beiliegendes Material (Beschlagbeutel Nr.) / Enclosed material (Fitting bag no.):

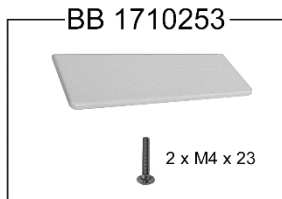
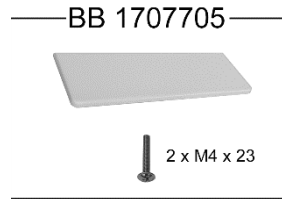
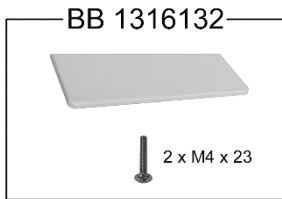
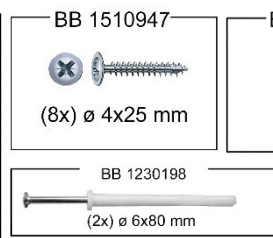
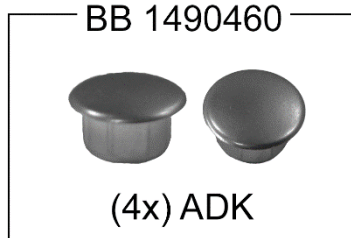
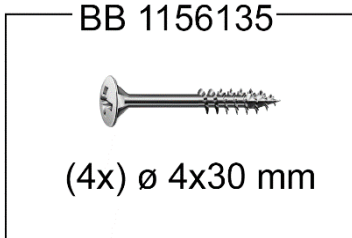

Modellbeispiele / Examples:

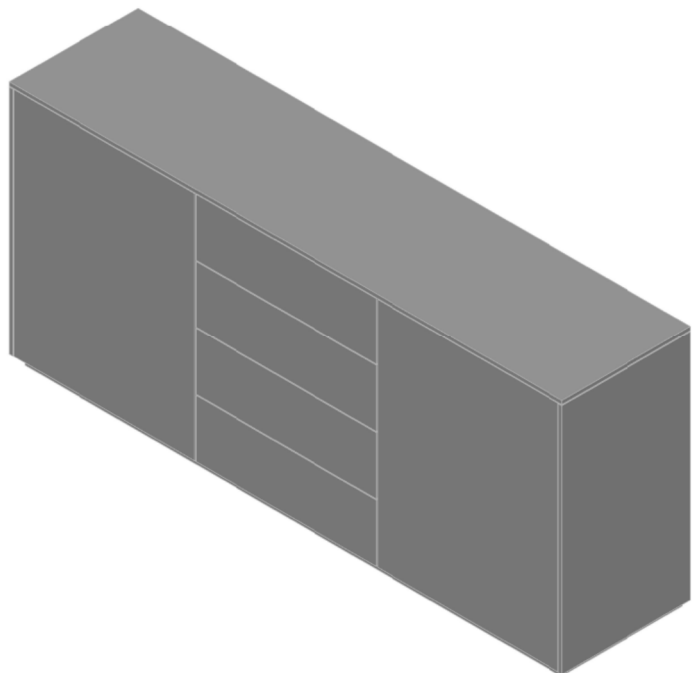
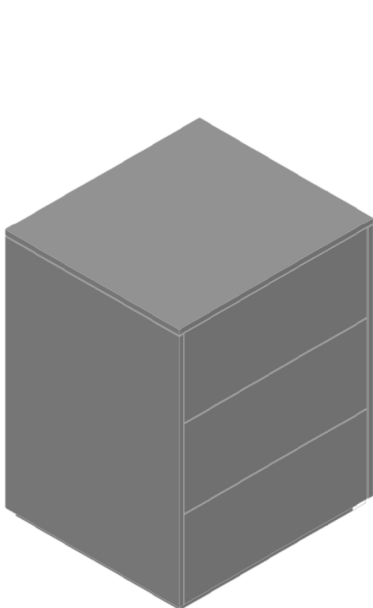

Konsolen + Kommoden / Consoles + chests of drawers

1 BB 1591497

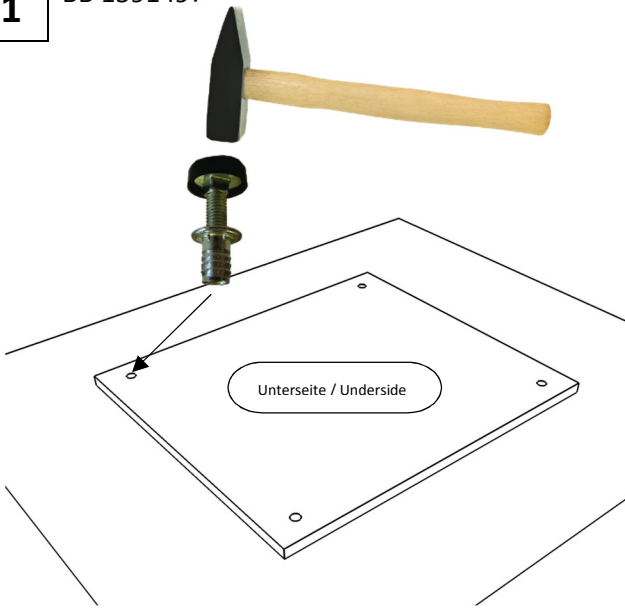

2

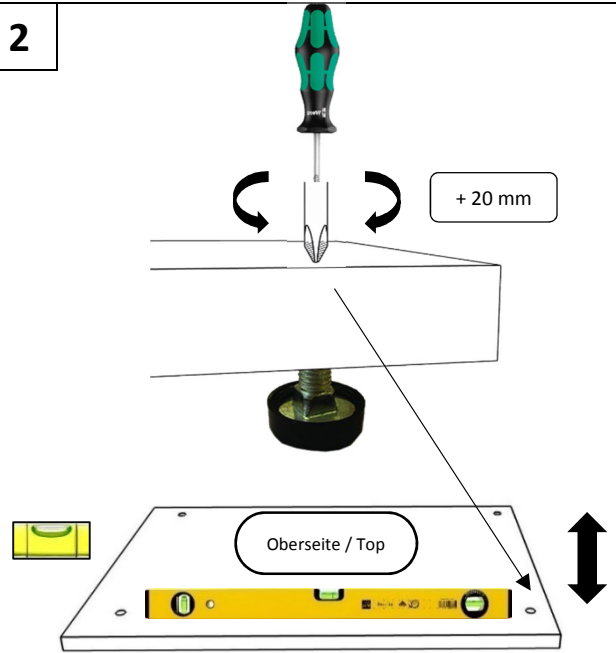

3

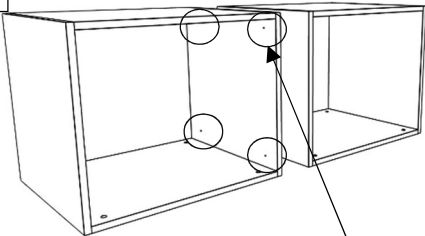

∅ 5 mm Holzbohrer/ Wood drill

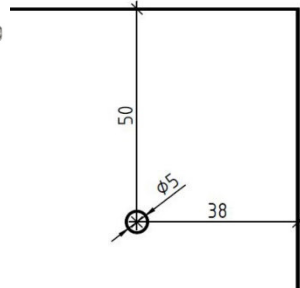

4

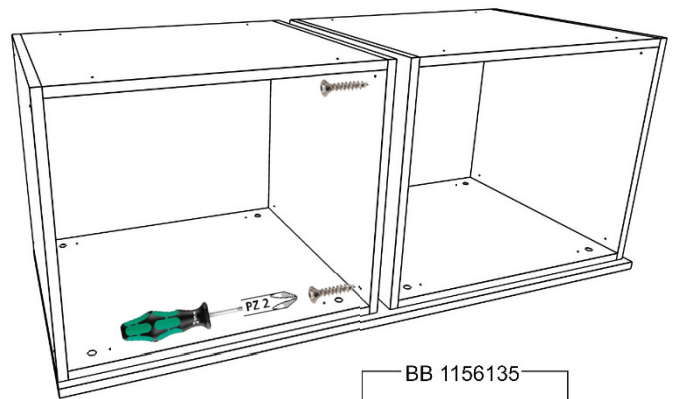

BB 1156135



(4x) ∅ 4x30 mm

5

BB 1156135



(4x) ∅ 4x30 mm

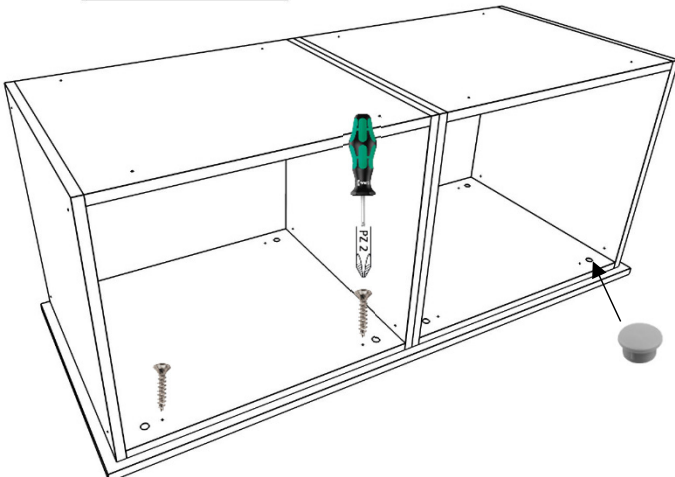

6

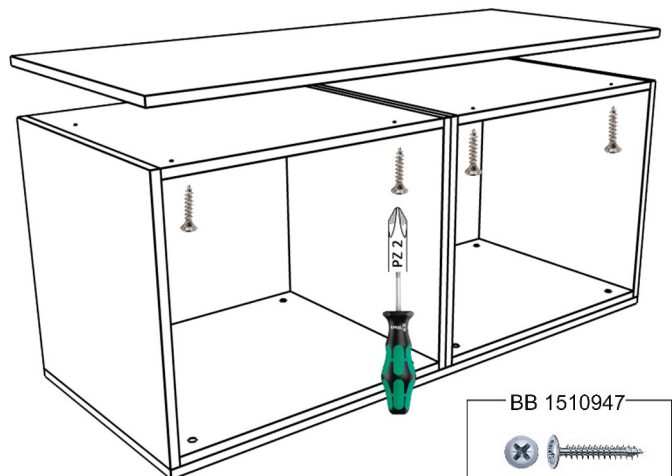

BB 1510947



(8x) ∅ 4x25 mm

Konsolen + Kommoden / Consoles + chests of drawers

7

$\varnothing 6$ mm
 Steinbohrer/ Stone drill

 BB 1230198
 (2x) $\varnothing 6 \times 80$ mm

8

1.
 Drücken!
 Press!
 2.
 Ziehen!
 Pull!

9

10

11

Drücken!
 Press!
 Ziehen!
 Pull!

12

+ 2 mm